



Integration of renewable energy into the transport and electricity sectors through V2G

Henrik Lund^{a,*}, Willett Kempton^b

^a Department of Development and Planning, Aalborg University, Fibigerstraede 13, DK-9220 Aalborg, Denmark

^b College of Marine and Earth Studies, University of Delaware, Newark, DE 19716, USA

ARTICLE INFO

Article history:

Received 18 March 2008

Accepted 2 June 2008

Available online 21 July 2008

Keywords:

V2G

Electric vehicle

Wind power

ABSTRACT

Large-scale sustainable energy systems will be necessary for substantial reduction of CO₂. However, large-scale implementation faces two major problems: (1) we must replace oil in the transportation sector, and (2) since today's inexpensive and abundant renewable energy resources have fluctuating output, to increase the fraction of electricity from them, we must learn to maintain a balance between demand and supply. Plug-in electric vehicles (EVs) could reduce or eliminate oil for the light vehicle fleet. Adding "vehicle-to-grid" (V2G) technology to EVs can provide storage, matching the time of generation to time of load. Two national energy systems are modelled, one for Denmark, including combined heat and power (CHP) and the other a similarly sized country without CHP (the latter being more typical of other industrialized countries). The model (EnergyPLAN) integrates energy for electricity, transport and heat, includes hourly fluctuations in human needs and the environment (wind resource and weather-driven need for heat). Four types of vehicle fleets are modelled, under levels of wind penetration varying from 0% to 100%. EVs were assumed to have high power (10 kW) connections, which provide important flexibility in time and duration of charging. We find that adding EVs and V2G to these national energy systems allows integration of much higher levels of wind electricity without excess electric production, and also greatly reduces national CO₂ emissions.

© 2008 Elsevier Ltd. All rights reserved.

1. Introduction

To mitigate climate change and reduce dependence on external energy supplies, many countries have adopted policies to increase both energy conservation and the share of renewable energy resources (Da Silva et al., 2005; Duic et al., 2003, 2005; Gross, 2004; Hvelplund and Lund, 1998; Lund et al., 1999, 2000, 2003, 2005; Toke, 2005). In some countries and regions e.g. in the EU such policies moreover include increasing the share of combined heat and power (CHP). With a high share of both wind power and CHP Denmark is one of the frontrunners in the implementation of such policies, and thus serves as valuable national case study of large-scale integration of new energy technologies.

Danish energy supply was traditionally based on the burning of fossil fuels. Denmark has very little hydro power potential and during the 1960s and 1970s the electricity supply came solely from large steam turbines located near the big cities. However, after the first oil crisis in 1973 Denmark has become a leading country in terms of implementing CHP, district heating, energy conservation and renewable energy. With these changes,

Denmark has been able to maintain the same total primary fuel consumption (for all uses, including transportation) for a period of more than 35 years. More than 15% of oil consumption has been replaced by renewable energy and even more by coal and natural gas, and consequently the Danish energy system has been changed from the situation in 1972, in which 92% out of a total of 833 PJ was oil, to the situation of 2006 in which only 40% is oil. In the same period both transportation, electricity consumption as well as the area of heated space have increased substantially. Today the share of Danish electricity production from CHP is as high as 50% on an annual basis, and approximately 20% of the electricity demand is supplied from wind power (Lund, 1999, 2000; Lund and Andersen, 2005; Lund and Ostergaard, 2000; Lund and Hvelplund, 1997; Maeng et al., 1999).

However, if Denmark is to proceed in replacing more fossil fuels by renewable energy, two problems arise. One is the transportation sector, which is almost totally fuelled by oil. Consumption was 140 PJ in 1972 and is expected to be 180 PJ or more in 2020. Thus the transportation sector will account for almost all the expected oil consumption.

The second problem is the integration of electricity production from CHP and wind power. Due to the relatively high wind penetration, and the fact that CHP was not operated for balancing until recently, Denmark has had problems of maintaining a

* Corresponding author. Tel.: +45 9635 8309; fax: +45 9815 3788.

E-mail address: Lund@plan.aau.dk (H. Lund).

Nomenclature			
D_{EV}	transportation demand of electric cars in TWh/year (demand from the grid)	$\eta_{Inverter}$	the efficiency of the battery to grid connection (inverter)
δ_{EV}	the distribution of the transportation demand in 8784 hourly values. (The numbers are relative e.g. each ranging 0–1.)	E_S	the capacity of the battery storage in GWh
P_{line}	the power capacity of the grid connection to vehicles in MW	$V2G_{Connection-Share}$	the share of parked V2G cars connected to the grid
$V2G_{DrivingShare}$	the maximum share of V2G cars which are driving during peak demand hour	e_{EV}	hourly transportation demand
$\eta_{Charger}$	the efficiency of the grid to battery connection (charger)	p_{V2G}	hourly power capacity of V2G grid connection
		e_{Charge}	hourly changing of V2G
		e_{CEEP}	hourly excess electricity production
		E_{S-min}	necessary minimum battery content
		e_{PP}	hourly power plant production on NON-CHP plants
		e_{Inv}	hourly electricity production from V2G

balance between electricity supply and demand. So far Denmark already has faced excess electricity production. As is known to those familiar with regions having high penetration of wind power, the problem of excess wind is more difficult to manage than insufficient wind. Excess wind is not a threat to system reliability, as it can always be “spilled” by feathering turbine blades. Rather, excess wind means that the system design has not achieved the best economic return on wind capacity investment and has not minimized emissions. The other aspect of electricity integration, more specific to Denmark, is the high proportion of CHP. Although efficient, CHP must be operated for heating, so during cold periods with low electric demand, CHP, like wind, may contribute to excess electricity production.

To minimize excess electricity production, Denmark has already implemented several measures, including changes in the regulation of distributed CHP plants (Andersen and Lund, 2007; Lund and Andersen, 2005). Additional technological options analyzed and considered to date include electric boilers and heat pumps (Blarke and Lund, 2007; Lund, 2003; Lund and Münster, 2003a), flexible demand, electricity for transportation (Lund and Münster, 2006; Mathiesen et al., 2008), reorganising energy conversion in relation to waste treatment (Münster, 2007) and various energy storage options (Mathiesen and Lund 2007).

“Vehicle-to-grid” (V2G) power technology is one of the many energy storage technologies, which may be part of making a flexible energy system that can better utilise fluctuating renewable energy sources. V2G is built on top of plug-in electric drive vehicles (EVs), which already displace petroleum by using electricity as the carrier for transportation energy. V2G refers to adding the capability to deliver power from the vehicle to the grid, but “V2G” is also used to imply that power flow, whether to or from the vehicle, is controlled in part by needs of the electric system, via a real-time signal. Consequently, the V2G technology provides potential solutions to both the problems mentioned above. Apart from two brief deterministic calculations (Kempton et al., 2007; Kempton and Tomic, 2005b) and one unpublished report of a US national model (Short and Denholm, 2006), there is no published model of how large-scale V2G would affect an entire national energy system.

This paper focuses on battery electric cars, but V2G may also be drawn from fuel cell vehicles or plug-in-hybrid vehicles. For battery cars, the grid-connected batteries charge during low demand hours and discharge when power is needed. Each vehicle must have three required elements: a connection to the grid for electrical power flow, control or logical connection for communication with the grid operator and auditable meters for power metering on-board the vehicles. The operational control logic must allow the grid operator some control, but override grid operator control in order to, for example, minimize battery wear or charge to prepare for vehicle operation. In other words,

reliability for the driver must be maintained for each individual vehicle, whereas reliability for the electric grid is obtained through aggregation of many vehicles. We assume vehicles with high power line connections (10 kW) because this provides flexibility when the vehicle is charged (as well as other operational benefits like fast recharge during lunch stops on trips). EVs with 20 kW charging and V2G are already in limited production. However, contemporary plug-in hybrids are typically much lower power, 1.5 kW, thus requiring overnight charging with little time flexibility. The concept of V2G has been described in detail in references (Kempton and Kubo, 2000; Kempton and Letendre, 1997; Kempton and Tomic, 2005a,b; Tomic and Kempton, 2007; Williams and Kurani, 2006, 2007), with the main governing equations derived in Kempton and Tomic (2005b).

2. Methodology

To evaluate V2G technologies in a national system integrating wind power requires detailed hour by hour system simulations, not performed in prior published studies. Such analyses have been carried out by the use of the EnergyPLAN computer model.

2.1. The EnergyPLAN energy system analysis model

The EnergyPLAN model is a general energy system analysis tool designed for analysing regional or national energy systems. It is an input–output model, which uses data on capacities and efficiencies of the energy conversions of the system and availability of fuels and renewable energy inputs. Hour by hour it calculates how the electricity and heat demands of the complete system will be met under the given constraints and regulation strategies. In such analyses the model has a library of wind power hour distributions based on actual historical power production from Danish wind turbines. Fig. 1 illustrates the functioning of the model, showing that it covers interactions among electricity, heat and transport fuels, although it concentrates on the electrical system. This makes EnergyPLAN suitable for the combined energy system analysis needed for the investigation undertaken here.

The result of the calculation is a quantitative knowledge of the production of the different units. From this, fuel consumption and fixed and variable operation costs can be calculated, subsequently, the system-economic costs and CO₂ emissions caused by meeting energy demands can be found. Internal transmission constraints are not modelled, whereas import and export of electricity can be, but for this exercise we assume an isolated electrical system. The model has previously been used in a number of energy system analysis activities, including expert committee work for the Danish Authorities (Lund and Münster, 2003a) and the design of 100% renewable energy systems (Lund, 2007b). More information

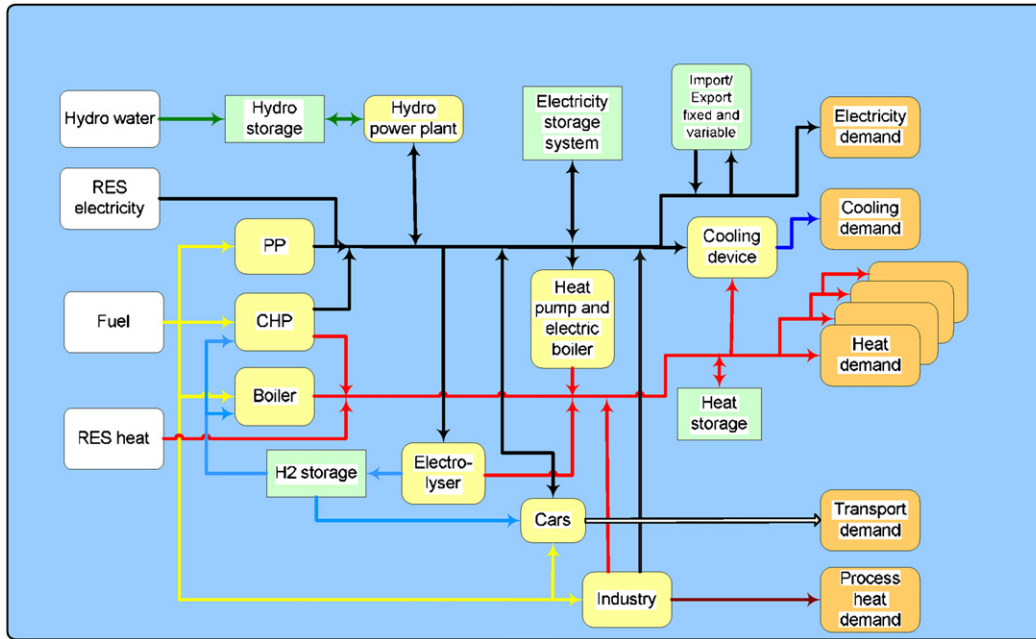

Fig. 1. The EnergyPLAN energy system analysis model.

on the model can be found in Lund (2007a) and Lund and Münster (2003b). The present version 7.0 of the EnergyPLAN model including documentation can be downloaded freely from www.EnergyPLAN.eu.

The EnergyPLAN model requires the following inputs to define EVs with V2G:

D_{EV} :	transportation demand of electric cars in TWh/year (demand from the grid)
δ_{EV} :	the distribution of the transportation demand in 8784 hourly values. (The numbers are relative e.g. each ranging 0–1.)
P_{line} :	the power capacity of the grid connection to vehicles in MW
$V2G_{DrivingShare}$:	the maximum share of V2G cars which are driving during peak demand hour.
$\eta_{Charger}$:	the efficiency of the grid to battery connection (charger).
$\eta_{Inverter}$:	the efficiency of the battery to grid connection (inverter).
E_S :	the capacity of the battery storage in GWh
$V2G_{Connection-Share}$:	the share of parked V2G cars connected to the grid.

All inputs are expressed for the entire utility system analyzed, and for the entire vehicle fleet within the service territory of that utility system. Thus, for example, the maximum system power capacity P_{line} is calculated as the line power capacity of a single car (per (Kempton and Tomic, 2005b)), multiplied by the maximum number of cars plugged in at any given time. Similarly, the entire set of batteries is modeled as one big battery, of fluctuating level of energy stored (E_S), charged through the line connection and discharged during driving as well as when returning V2G power to the grid.

One important input is the distribution of the transportation demand (δ_{EV}), which is used for two purposes. One is to determine how many V2G cars are driving and consequently not connected to the grid. This, together with the $V2G_{DrivingShare}$ (the maximum share of V2G cars that are driving during peak demand hour) and the $V2G_{Connection-Share}$ (the share of parked cars that are actually plugged in during any one hour) determines the fraction of the V2G fleet that is available to the electrical system at any given hour. The other purpose for δ_{EV} is to determine the discharging of the battery storage for driving.

2.2. Modeling of transportation demands and charging capacities

The hourly transportation demand and thereby the discharging of the battery (e_{EV}) is calculated as follows:

$$e_{EV} = [D_{EV} \delta_{EV} / \sum \delta_{EV}] \eta_{CHARGE} \quad (1)$$

And the grid-connection power capacity of the total V2G fleet on an hourly basis (p_{V2G}) will be calculated as follows:

$$p_{V2G} = P_{line} V2G_{Connection-Share} ((1 - V2G_{DrivingShare}) + V2G_{DrivingShare} (1 - \delta_{EV} / \text{Max}(\delta_{EV}))) \quad (2)$$

This formula consists of three factors. The first factor is P_{line} , the power capacity of the entire V2G fleet. This is multiplied by $V2G_{Connection-Share}$, the fraction of the parked vehicles that are plugged in. The third factor, in parentheses, calculates the fraction of vehicles on the road at each hour. Further decomposing the third parenthesized factor, it consists of the sum of two terms. The first term, $(1 - V2G_{DrivingShare})$, represents the minimum fraction of vehicles parked. The second term is the additional fraction of the vehicles parked during non-rush hours. The hourly fraction of vehicles parked is derived from the known input of hourly energy demand for the fleet. This formula yields p_{V2G} , the power capacity of all connected V2G vehicles, at any given hour. This is a calculation of aggregate power capacity from the line capacity and the plugged-in vehicle count, but not considering whether sufficient battery charge is available; the latter is treated in the next section.

The calculation works as described in the following hypothetical example of 1.9 million cars, each with a grid connection of 10 kW and each with a demand of 2 MWh/year in order to drive 20,000 km/year. The charger and inverter efficiencies are each defined as 0.9, that of a high-efficiency charger/inverter. In total, the demand for transportation becomes $D_{EV} = 3.8$ TWh/year, for an average draw of 434 MW. If we unrealistically assume that about half of the cars are used for commuting during rush hours, the distribution of the power use is a peak demand by drive trains during rush hours between 7:00 and 9:00 in the morning and between 16:00 and 18:00 in the afternoon, as shown in Fig. 2 for 1 week. (Recall that this is battery demand, not electric system

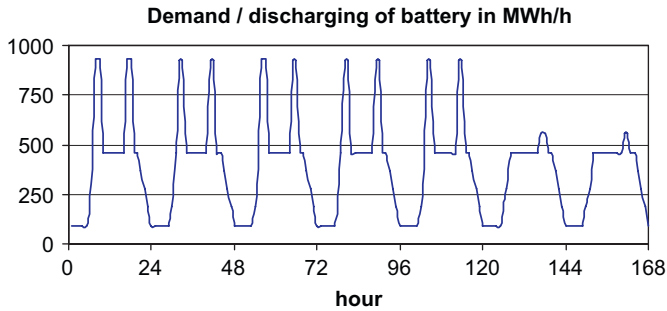

Fig. 2. Transportation demand and thereby discharging of battery during 1 week; hypothetical data assuming that over half the cars are used for commuting, at the same commuting hours.

demand, as the vehicles are necessarily disconnected from the grid while driving.)

Based on such inputs, the model will calculate the distribution of the demand and thereby also the discharging of the battery, as shown in the next diagram. The integration of the area under the curve throughout a year to obtain energy drawn from electric plugs yields 3.42 TWh/year, calculated from 0.9×3.8 TWh/year.

The range and temporal variation of p_{V2G} , the aggregate national plug connection capacity, is an important parameter but has not previously been studied. In the limiting case, if at one instant all 1.9 million cars were connected at 10 kW, the maximum instantaneous power would be 19 GW. To model this more realistically, the temporal variation of p_{V2G} is a function of δ_{EV} , and the two parameters $V2G_{DrivingShare}$ and $V2G_{ConnectionShare}$.¹ For the simple but unrealistic assumption that both parameters are 100% (input as 1.0), the variation in power connection over a modeled week is as shown in the uppermost diagram of Fig. 3. ($V2G_{DrivingShare}$ is in the figure called $V2G_{Max-Share}$.) In such case, the model assumes that all vehicles are driving during peak transportation demand and, consequently, the grid connection becomes zero. During low transportation demand, the grid connection approaches the maximum grid connection P_{line} , subtracting the few vehicles that are driving.

Contrary to what one might imagine if stuck in rush hour traffic, even during peak transportation demand in industrialized countries, only a small proportion of the vehicles are driving. This proportion is the parameter, $V2G_{DrivingShare}$. The remaining cars are parked and potentially connected to the grid at peak driving times. In Fig. 3 (the diagram in the middle), the $V2G_{DrivingShare}$ has been defined to 20%, representing a minimum of 80% of all cars are parked during rush hours. Since prior research on the United States (Kempton et al., 2001) and Japan (Kempton and Kubo, 2000) find slightly higher proportion of vehicles are parked, setting $V2G_{DrivingShare} = .20$ is conservative, that is, it will slightly underestimate the power capacity of the grid connection.

In the lowermost diagram of Fig. 3, the input of the share of parked vehicles that are connected, $V2G_{ConnectionShare}$, has been changed from 100 to 70% and, consequently, the grid connection is decreased in general by 30% compared to the middle diagram of Fig. 3. For typical driving patterns, and if we assume some financial incentive to stay plugged in when parked, we believe that the parameters used to produce the lowermost diagram of Fig. 3 are reasonable.

This set of three figures illustrates the value of the model. Whereas one might imagine that storage in vehicles would be an unreliable grid asset because it would fluctuate widely with

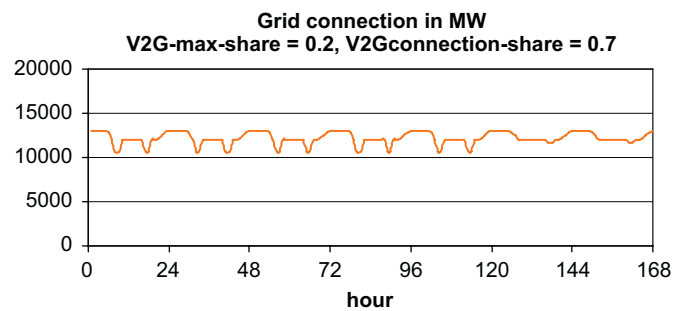
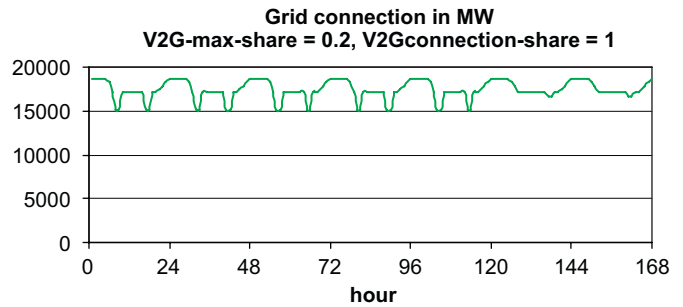
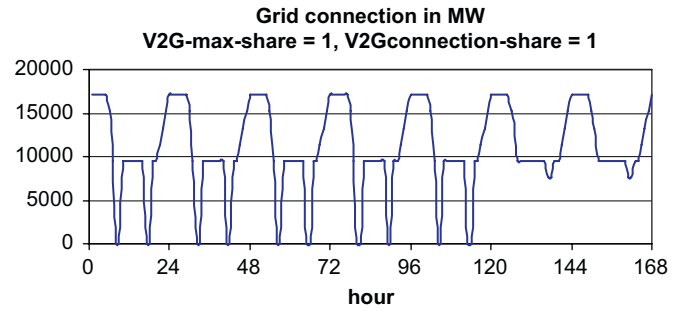

Fig. 3. Modeled fluctuation in the power of the grid connection through 1 week, for three different combinations of the two input parameters $V2G_{DrivingShare}$, and $V2G_{ConnectionShare}$.

traffic, when the model is run on realistic driving parameters, and with the assumption that rate incentives motivate plugging in 70% of the time when parked, we find that the system aggregate power connection to the model big battery is relatively constant. Specifically, with 10 kW per car line capacity in a country the size of Denmark, the grid connection varies within the range of 10–13 GW.

2.3. Considerations on the modeling of the batteries and loading before disconnecting

As noted previously, the batteries of the EV fleet are modeled as if there were one big battery for the entire vehicle fleet. The battery capacity is modeled as being equal to the sum of all individual batteries. In reality, the total capacity of the battery is not available all the time, since some of the cars will be driving, and can neither discharge to, nor charge from, the grid; others will need to drive in the next few hours and thus cannot be discharged. The model assumes for simplicity that the batteries for the cars are scheduled to be fully charged when they disconnect and start driving. Consequently, the model would not gain much from keeping separate account of the proportion of the big battery that is not connected at each hour, since this part would typically within the hour have been fully charged anyway. For the small fraction of cars driving for more than 1 h, they will discharge a bit from 1 h to another, leading to lower total charge in reality than

¹ In the notation of Kempton and Tomic [31], the combination of these two parameters would be expressed in hours/day as t_{plug} , the hours/day for which the car is both parked and plugged in.

modeled here. Another assumption is that cars are grid-connected when not driving, in other words, that locations of long daytime parking, such as employer lots and mass transit stations, would have grid connections. In fact, for some daytime parking locations this may not be practical. If one wanted to approximate such factors in the model, one could simply make a small reduction in the input value for the capacity of the battery, E_S .

The model is required to make sure that the individual car is fully charged before disconnect. For the night charge BEV, this is accomplished by the simple means that the vehicle is fully charged early each morning (regardless of time of day of first daily trip). For the Intelligent Charging and the V2G cases, the batteries are charged during times the grid has excess electric power production. However, when there is not excess power production, the model has to make sure that the batteries are fully charged prior to driving periods.²

The model assumes that the scheduler on each car is 100% accurate about when the driver will need to drive again. Therefore, the scheduler is assumed to prioritize charging for the cars that will drive again within the next few hours, so if there is only a small amount of excess wind, it is directed to the cars that will be in use next. That is, during each hour, the model inspects the next e.g. 2 hours' driving needs, and if there is not enough in the big battery to fill the batteries of these cars completely, then the charging is forced even in the case of lack of excess production. Specifically, if needed, fossil fuel power plants will be switched on if there is not enough excess wind. Thus the simplifying assumption that each car about to drive must be fully charged, regardless of range need, increases CO₂ emissions in the model, and reduces unfilled battery storage thus reducing ability to absorb excess electricity.

Alternative methods for identifying the charge level needed at trip start, not modeled here, include predictive scheduling by an on-board module for driver tracking, or the individual car owner choosing between low costs of charging or revenue from V2G versus security of fully charged batteries. The car owner could do this by setting price thresholds and/or limitations to override the computer control of the car (Kempton and Letendre, 1997). (Note: Even where electricity prices are high and petrol prices include little tax, as in the United States, electricity is far less expensive than petrol, e.g. 1/5 the cost per mile.)

In the model, the necessary hours of "pre-charging" is found by trial-and-error. The model starts by assuring that the battery always has a minimum charge only that needed to supply driving 1 h in the future; if this results in lack of battery content the number is raised to 2 h, etc. The number of hours becomes a result of the calculation. In an optimized electric control system, the number of hours prior to driving might also be determined system wide by weather forecasts regarding anticipated wind for the next few hours, and for individual cars, precharging need might be determined by factors such as that driver's predictability of next trip. We do not consider such refinements here.

2.4. Modeling of V2G control strategies

For each hour, the model calculates as follows. The V2G cars are told to charge where there is excess electricity production for that hour (e_{CEEP}), and available battery energy capacity for that hour ($E_S - e_S$) within the limitations of the hourly power capacity of vehicles connected (p_{V2G}). (Note: Lower case energy units are

calculated for each single hour.) Thus, the hourly amount of added charge takes the minimum of these three values:

$$e_{\text{Charge}} = \min[e_{\text{CEEP}}, (E_S - e_S)/\eta_{\text{Charge}}, p_{\text{V2G}}] \quad (3)$$

(Note: Since the model runs on an hour-by-hour basis, power units such as p_{V2G} , expressed in MW, are implicitly multiplied by 1 h to yield units of MWh.)

Moreover (as mentioned above), the charging is forced in the case in which the transport demands of the present and the next "y" hours cannot be supplied by the battery content. Initially, the "y" value is set to 1 h. As noted above, if this leads to lack of battery content the value is raised in steps of 1 h.

The necessary minimum battery content is calculated as

$$E_{S-\text{min}} = \sum e_{\text{EV}} \quad (4)$$

$$x = a$$

$$a + y$$

Then the charging of the battery is adjusted accordingly, by requiring that

$$e_{\text{Charge}} \geq [E_S - E_{S-\text{min}}]/\eta_{\text{Charge}} \quad (5)$$

If e_{Charge} becomes higher than the capacity of the grid connection p_{V2G} then the number of hours, y , is raised by one, and the calculations starts all over again. The new battery content is then calculated by adding the above charging and subtracting the discharging caused by driving (e_{EV}):

$$E_S = E_S - e_{\text{EV}} + (e_{\text{Charge}}/\eta_{\text{Charge}}) \quad (6)$$

The V2G cars are told to supply to the grid in the case of potential replacement of production from power plants (e_{PP}) and available stored electricity in the battery after supplying the transportation demand:

$$e_{\text{Inv}} = \min[e_{\text{PP}}, ((E_S - E_{S-\text{min}})\eta_{\text{Inv}}), p_{\text{V2G}}] \quad (7)$$

And the resulting new battery content is then calculated as follows:

$$E_S = E_S - (e_{\text{Inv}}/\eta_{\text{Inv}}) \quad (8)$$

To correct the calculations from errors due to differences in the battery storage content between the beginning and the end of the calculation period (one year), the above calculation is repeated until the storage content in the end is the same as in the beginning. Initially, the storage content is defined as 50% of the battery storage capacity. After the first calculation, a new beginning content is defined as the resulting content in the end of the former calculation. Such procedure is repeated until the difference is insignificant. Typically the model only needs to run twice through the calculation period to make a balance.

3. Data and assumptions

For the analysis we define two national energy systems and four vehicle fleet alternatives. The four fleets are combustion cars in the reference case, compared with three cases of battery electric vehicles: night charging, intelligent charging and intelligent charging with V2G.

3.1. Two example national energy systems

Two national energy systems are selected for the analysis of the potential influence from BEV's with V2G on the integration of renewable energy into the transport and electricity sectors. The first reference energy system has a high share of CHP production, much like that of Denmark as projected for 2020.

² In a future refinement of the model, we may assume that the vehicle controller is able to infer how much vehicle range is needed and would not fully charge when: there is no excess production and vehicle use is highly regular. For example, if intercity trips are taken only on Saturdays, the battery would not need to be fully charged for weekday mornings.

In 2001, on request of the Danish Parliament, the Danish Energy Agency formed an expert group to investigate the problem of excess electricity production arising from the high percent of wind power and CHP in the Danish energy system (Danish Energy Agency, 2001). As part of the work, Aalborg University made some long-term year 2020 energy system analyses of investments in more flexible energy systems in Denmark (Lund and Münster, 2001). These analyses were carried out on the EnergyPLAN energy system analysis computer model. As reference for the analysis the expert group defined a Danish future year 2020 energy system in accordance with Danish long-term energy policies and strategies. Compared to the present situation, the reference case is constituted as

- Danish electricity demand is expected to rise from 35 TWh in year 2001 to 41 TWh in year 2020 equal to an annual rise of approximately 0.8%.
- The installed capacity of wind power in year 2001 is expected to rise from 570 to 1850 MW in East Denmark and from 1870 to 3860 MW in West Denmark in year 2020. The increase is primarily due to the implementation of one 150 MW off shore wind farm each year.
- Existing large coal-fired CHP steam turbines are replaced by new natural gas fired combined cycle CHP units when the lifetime of the old CHP plants is exceeded. Additionally, small CHP plants and industrial CHP are due to a small expansion.

In 2001 the expert group conducted the analyses separately on the western and the eastern parts of Denmark, which have separate electricity grids. For practical reasons the analysis in the following has been made for a joined system including all of Denmark. Moreover, the expert group only included analyses of the electricity system. Here, for a more integrated energy system view, data for the rest of the energy sectors including the transport sector have been added on the basis of the former Danish governmental energy plan “Energy 21” (Danish Government, 1996).

The Danish reference case, with its high share of CHP, is not typical for most countries. Therefore, a NON-CHP reference has been defined simply by replacing all CHP in the Danish system by heat production from district heating thermal boilers and electricity production from power stations. The second national reference system is set at the same total size as the Danish energy system, for comparison purposes. The parameters of the two reference systems are listed in Table 1.

Table 1
Reference national energy systems (units are TWh/year)

	CHP system (Denmark 2020)	Non-CHP system
<i>Key figure</i>		
Electricity demand	41.09	41.09
District heating demand	39.92	39.92
Excess electricity production	8.41	0.93
<i>Primary energy supply</i>		
Wind power	17.72	17.72
Fuel for CHP and power plants	92.29	102.32
Fuel for households	19.67	19.67
Fuel for industry	20.22	20.22
Fuel for transport	50.68	50.68
Fuel for refinery, etc.	17.39	17.39
Total	217.96	228.00

In the EnergyPLAN model different limitations on power plant regulation can be defined. Here the analyses assume that the power plants can change production from 1 h to another to compensate fluctuations in wind power. However, a limitation of a minimum capacity of 550 MW (4.8 TWh/year) has been defined. Such limitation represents a system of steam turbines as the Danish in which always 5–6 power plant units is above technical minimum production. In the analyses, such minimum capacity has been applied to both the CHP and the NON-CHP system. In the CHP system the CHP units are operated to meet heat demands only, not regulation.

3.2. Transport demands and vehicles

The modeling of transportation demands is based on Danish statistics. In year 2001 the number of private cars in Denmark between 800 kg and 2 ton were 1,872,631 and they were used to drive 38,036 million vehicle km leading to an average of 20,300 km/year per vehicle. Based on an average of 14 km/l gasoline each car consumed 1450 l/year. Consequently, the reference is constituted by 1.9 million combustion cars each driving 20,000 km/year and in total consuming 2700 million liter gasoline equal to 25.5 TWh/year. The reference combustion vehicle fleet is compared to four electric vehicle alternatives:

- REF: Reference combustion vehicle fleet
- BEV: Battery Electric Vehicles, with Night Charge
- InBEV: Intelligent Battery Electric Vehicles
- V2G: Vehicle to Grid cars
- V2G+: Vehicle to Grid cars with 3 × larger battery

All but the combustion case will sometimes be referred to as EVs. All EVs except V2G+ (discussed later) are assumed to have a battery of 30 kWh and a grid connection of 10 kW. The EVs have an efficiency of 6 km/kWh³ and consequently consume 3333 kWh/year in order to drive 20,000 km. Based on such statistics and assumptions, the reference fleet and three alternative vehicle fleets have been defined as shown in Table 2.

The charging of the night charge BEV is assumed to be done following the charging schedule shown in Fig. 4. This is based on vehicles starting to charge after 4 pm and when plugged in, and continuing slowly until the battery is fully charged. The control to accomplish this could be as simple as a plug with a timer, or a utility-supplied time-of-day meter that, for a lower cost per kWh, only allows electricity use overnight. The night charge ramp up is modeled for the big battery in the aggregate, but it can equally be thought of as a proxy for gradually increasing the number of vehicles connected, then decreasing charge as they start becoming fully charged.

Unlike the night charge, the InBEV and V2G charging is based on signals from the electric system as described above. The InBEV recharges as much as possible when there is excess power. The V2G does this, and additionally provides power back to the grid when there is not enough power, from power plants, wind or running CHP plants.

For the aggregated national demand for transportation, we used time-specific driving data from the US (data for transportation demand for the model here draws from table A-12 “Distribution of Trips by Time of Day, in Percent” of US Department of Transportation Statistics (US Department of

³ The all-electric two-seat Tesla Roadster claims 110 wh/km or 9 km/kWh (www.teslamotors.com). However, for a four-passenger light-weight sedan, 6 km/kWh is more realistic; for example, this is the road efficiency of the AC Propulsion eBox demonstrated in our tests at the University of Delaware.

Table 2
Input parameters of transportation reference case and three alternatives

	REF Reference	BEV Night charge	InBEV Intelligent charge	V2G Vehicle to grid
Number of vehicles	1.9 million	1.9 million	1.9 million	1.9 million
Average use	20,000 km/year	20,000 km/year	20,000 km/year	20,000 km/year
Vehicle efficiency	14 km/l	6 km/kWh	6 km/kWh	6 km/kWh
Gasoline consumption	25.5 TWh/year	6.33 TWh/year	6.33 TWh/year	6.33 TWh/year
Electricity consumption		19 GW	19 GW	19 GW
Charging capacity		57 GWh	57 GWh	57 GWh
Battery storage				19 GW
Discharging capacity				

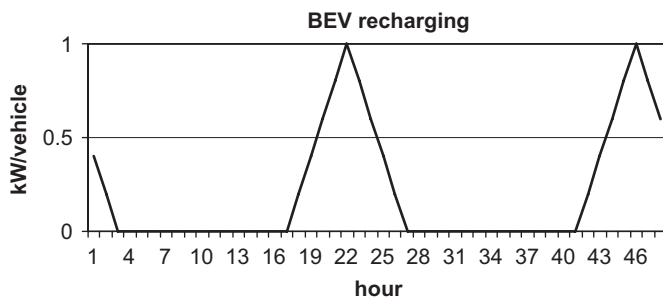

Fig. 4. Charging of night charge BEV. The cycle is repeated.

Transportation, 2003)). Although driving patterns may be somewhat different in Denmark and the US, we felt that real hourly data were better than a simulation or assumptions. Previously, in Fig. 2, we illustrated the method for a hypothetical fleet in which we assumed a large fraction of vehicles were commuting during rush hours. Fig. 5 shows actual transportation demand, which we use in the analysis undertaken. (Fig. 5 shows that rush hours comprise under 1.1% of weekly travel demand, thus under 8% of daily demand—this suggests, consistently with the previously cited references, that over 90% of cars are parked at any hour.) These transportation demand data are used in combination with a 70% connection share and a conservative 20% share of cars driving (not parked) during rush hours as explained above.

4. Results

In both the CHP and the NON-CHP system the impacts of EVs and V2G are calculated for a range of wind power from 0 to 45 TWh/year, on a national system the size of Denmark. A total of 45 TWh/year would be approximately 100% of Danish national electrical demand in 2020, including the electric vehicles; it is the equivalent of an average power output of 5.2 GW. (Without the electric vehicles, 2020 demand would be 41 TWh.) The energy system analyses provide results for all units in every hour of the year.

The model results for the entire energy system are given here in graphs of two critical measures—annual excess production and CO₂ emissions. Low excess production is a measure of whether high fractions of wind are effectively achieving revenue and reducing CO₂ emissions, without need for more intercountry transmission.

Consider first the top of Fig. 6, excess electricity production in the CHP system. As the fraction of wind power increases beyond about 5 TWh, the excess production of electricity increases. Following the dark line for the REF case, at 10% wind (about 5 TWh), there is a little excess, whereas at 50%, (22.5 TWh) a

substantial fraction of the wind power is excess production. The other lines show that excess production is reduced successively by BEV with night charge, BEV with intelligent charging and with V2G. Most simply, the excess production decreases in part because cars are an added load, themselves increasing electricity demand from 41 TWh/year to approximately 47 TWh/year. Additionally, each refinement of the vehicle fleet successively reduces excess production. The combined reductions are significant. For example, in the 50% wind scenario, changing from the reference combustion fleet to V2G reduces excess electricity production by one half.

The BEV with night charge does better than one might expect, significantly reducing both excess production and CO₂ emissions (Fig. 6, bottom). From the night charge line the incremental benefit to intelligent charging and from there to V2G are small. These results suggest that the ability of EVs to absorb excess power from wind may be at least as important as their ability to return bulk power at times of need. However, the small additional decrement via V2G is also due in part to the model assumptions at this point. The “night charge” is actually more intelligent than current plug-in vehicles, as our model assumes charging only after 5 pm, when there is likely to be more excess production and a higher fraction of power is from wind. Also, the small incremental benefit from intelligent charging to V2G is due in part to our not yet including the ability of V2G to provide regulating power.

The bottom half of Fig. 6 shows CO₂ emissions in the CHP system. The reference (combustion) vehicle case, the solid dark line, shows that with no electrical vehicles, increasing wind generation reduces CO₂ emissions. However, the slope of CO₂ reduction begins to level off about 10–15 TWh of wind and is almost flat by 3/4 wind (33 TWh). Again, the addition of night charge BEV and more so intelligent charging and V2G will all substantially reduce the CO₂ emissions.

The leftmost edge of Fig. 6 (bottom), with 0 TWh of wind, depicts the CO₂ impact from the replacement of petroleum-fueled cars to electric cars. The 0 point shows how much reduced CO₂ is achieved by displacing petrol. This 0 wind reduction is substantial—despite the power plants being fueled by fossil fuel—due to the much better vehicle efficiencies (one electric vehicle displaces 13,000 kWh of gasoline with 3333 kWh electricity). This band between REF and V2G grows as the proportion of wind power increases, because an electric fleet has increasingly beneficial CO₂ impact as more electricity comes from wind. In Fig. 6 the REF-V2G band on the right is almost twice the height that it is at the left edge, and we will see in Fig. 7 that the right band is more than twice the height as the left. This means that the direct CO₂ reduction from completely eliminating motor fuels is less than the indirect effect that EV and V2G have on reducing CO₂ from electric generators. In Fig. 7 the results are shown for the NON-CHP system. The NON-CHP system is more typical of

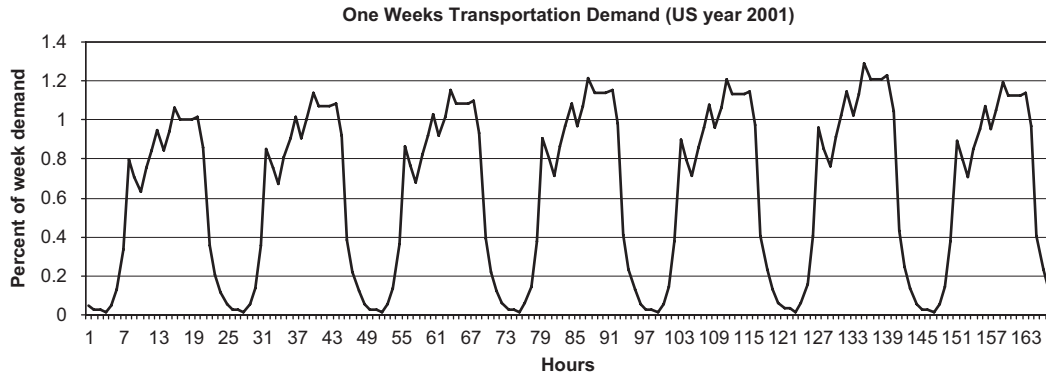

Fig. 5. Hour distribution of the transportation demand based on US statistics.

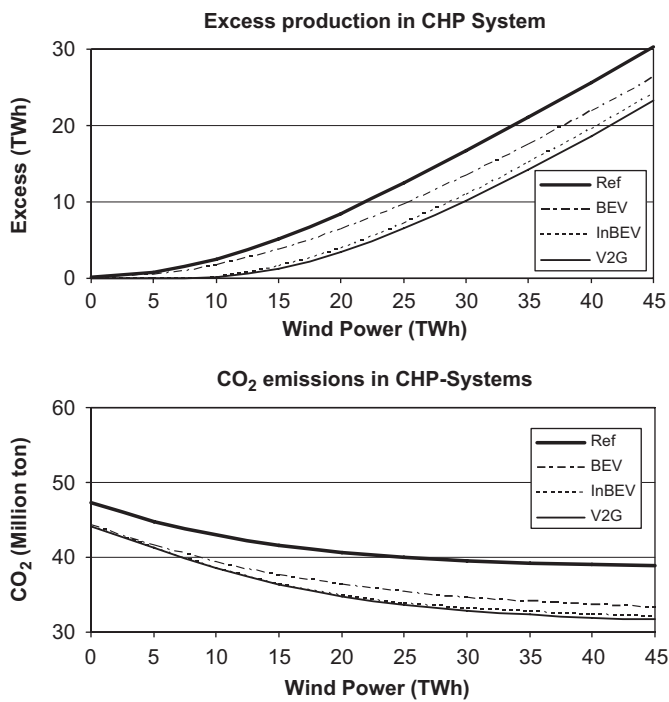

Fig. 6. CHP system, annual excess electricity production (top) and CO₂ emission (bottom) as electricity from wind power increases.

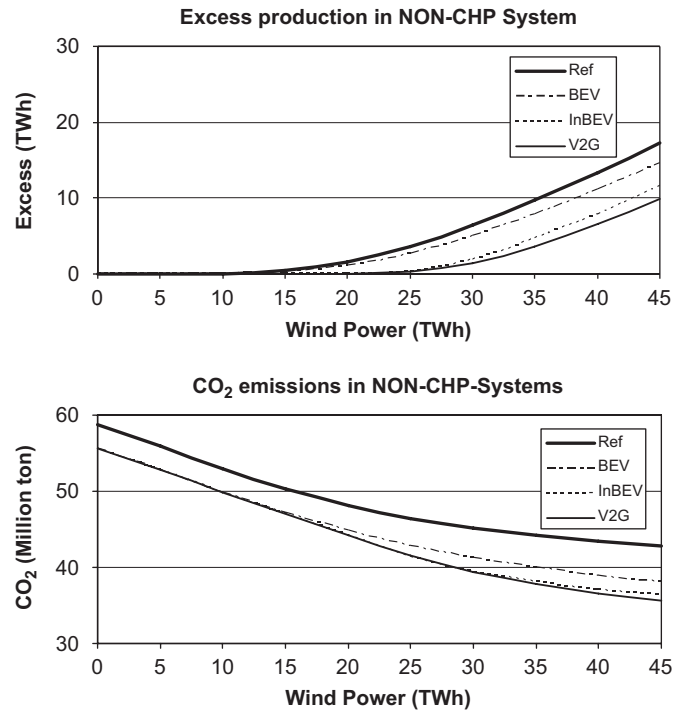

Fig. 7. NON-CHP system, annual excess electricity production (top) and CO₂ emissions (bottom) as electricity from wind power increases.

industrialized countries, with heat provided by independent devices (in this case district heating) rather than combined with power plants. CHP is more efficient, so at the base of 0 wind power, the CHP system has considerably less CO₂ emissions, and this continues throughout the range of wind power levels. (Given the assumptions of the model, including that fuel is burned for building heat in the NON-CHP system, and given that the CHP model is based on Denmark, with its high 50% of annual electric demand produced in CHP.) On the other hand, excess electricity production begins earlier in the CHP system, before reaching 5 TWh of wind (for combustion cars), and the excess is considerably higher at high wind power production. This is because electricity production from CHP adds to the excess wind production. To avoid excess CHP production, one will have to replace heat production from CHP by peak load boilers that do not produce electricity—at low wind fraction this will miss the fuel efficiency of CHP, although at high wind fraction, heating could run from wind electricity—not modeled here—further lowering CO₂.

The addition of EVs has a larger effect, proportionally, in the NON-CHP system. Even at high wind fractions, say $\frac{3}{4}$ of electricity or 34 TWh from wind, with V2G there is still 12 TWh of excess in CHP but only 4 TWh excess in NON-CHP.

The introduction of all types of EVs leads to reduction of both excess production and CO₂ emissions for high shares of wind. However, the influence does not nearly zero out either excess production or CO₂. The flatter lines toward the right mean that the beneficial effects of the EVs are incrementally less as the fraction of wind moves higher.

One important factor in this limitation is the capacity limitation in the battery storage. In Fig. 8 the impact of a V2G fleet with our base characteristics has been compared to the impact of a V2G fleet with a storage capacity three times higher (here called V2G+), i.e. 90 kWh/vehicle or 171 GWh all together. A 90 kWh vehicle would be sensible in that it would have a 540 km range and thus would more completely substitute for a liquid-fuel or plug-in hybrid vehicle. (It would not be practical today due to battery cost as well as battery weight, but the

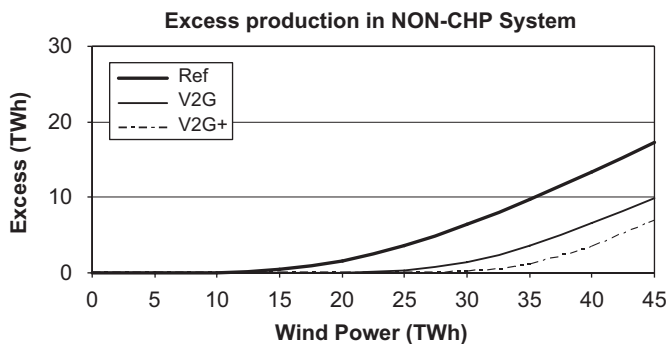

Fig. 8. V2G impact on annual excess electricity production in the NON-CHP system compared to a system with three times higher battery storage capacity (V2G+).

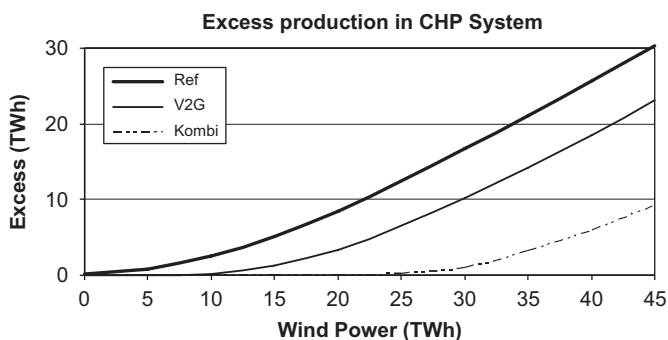

Fig. 9. V2G impact on annual excess electricity production in the CHP system compared to a system in which V2G cars are combined with active regulation of CHP plants including heat pumps and heat storage (Kombi).

technology is improving rapidly.) As seen in Fig. 8, such increase in the storage capacity significantly reduces excess consumption (and CO₂ emissions, not shown here).

Additional limits on the model are that it assumes that the CHP plants are not included in the regulation of wind power and the small CHP plants do not contribute to the fulfillment of maintaining grid stability. To examine the effect of the first of these, the same analysis has been conducted for alternative situations in which the CHP plants are included in the regulation and in which heat pumps and heat storage capacities have been added to the system. From several analyses, heat pumps in combination with heat storage and CHP have proven to be a very efficient technology in the integration of wind power. Heat pumps adds the possibility of consuming excess electricity at the same time as it produces heat and thereby allow the CHP units to stop. Consequently, such investments decrease the excess production as well as the CO₂ emissions in general. However, the results of including BEV and V2G are similar in all alternatives.

In Fig. 9 is shown how the combination of V2G with active regulation of CHP plants including heat pumps and building heat storage together (called here “Kombi”) will significantly reduce excess electricity production for even very high shares of wind power.

All together the analyses show that EVs with at least night charging, and more so V2G, will improve the efficiency of national energy systems, reduce CO₂ emissions and improve the ability of those systems to integrate large proportions of wind power. Moreover, V2G can be combined with other measures such as heat pumps and active regulation of CHP plants, so that they together form a coherent solution to the integration of wind power into sustainable energy systems.

5. Conclusion

This paper has designed a suitable modeling of electric vehicles with three types of controls, in order to conduct detailed hour by hour overall system analyses of the impact of V2G on national energy systems. The model has been applied to two national energy systems, one without CHP and the other with a high share of CHP, the latter based on Denmark. For both systems, the model is run for 100% electric vehicles, assuming high power (10 kW) and substantial on-board storage (30 kWh), and with national electrical demand increased accordingly. The impacts of EVs are calculated for a range of wind power from 0 to approximately 100% of the electricity demand, and for the reference case of combustion vehicles, as well as four variants of electric vehicles.

Altogether the analyses show EVs with night charging, and more so with increasing intelligence including V2G, will improve the efficiency of the electric power system, lower CO₂ emissions and improve the ability to integrate wind power. In a less detailed final analysis, V2G was combined with other measures such as heat pumps and active regulation of CHP plants, showing that end use integration, combining building and transportation end-uses, can form a coherent solution to the integration of wind power into sustainable energy systems, and that very high levels of wind power are possible, even without centralized storage or regional electric interties. (Denmark is connected by transmission North and South, and would deal with “excess” by selling electric power; our model assumes no international electric transfers in order to understand how to minimize the need for them.)

The assumptions in this first application of the national energy model to V2G are conservative, that is, these assumptions probably lead to underestimate the value of V2G. First, the most important advantage of V2G over simple EVs may be complete replacement of regulating power stations, using V2G to provide grid stability (both voltage and frequency). Such benefit has not been included in the model analysis for this paper. Second, it was assumed that the vehicle V2G controllers were not smart about their drivers’ operating schedule, thus they were required to fully charge the battery each morning. Thus more power plant operation was required during nights with little excess electricity, and less battery capacity was available during the day to absorb excess. These are possible future refinements to the model and analysis. Despite the conservative effects of these simplifying assumptions, an EV fleet with some intelligence (at a minimum night charging, ideally with V2G) appears to move us much closer to low-carbon national energy systems. Intelligent EVs can help minimize excess production and CO₂ emissions. V2G, along with some end-use heat storage and management, constitute a carbon-free and far lower-cost alternative to expansion of fossil generators for balancing, or to building dedicated centralized storage.

References

- Andersen, A.N., Lund, H., 2007. New CHP partnerships offering balancing of fluctuating renewable electricity productions. *Journal of Cleaner Production* 15 (3), 288–293.
- Blarke, M., Lund, H., 2007. Large-scale heat pumps in sustainable energy systems: system and project perspectives. *Thermal Science* 11 (3), 141–152.
- Da Silva, E.P., Marin Neto, A.J., Ferreira, P.F.P., Camargo, J.C., Apolinario, F.R., Pinto, C.S., 2005. Analysis of hydrogen production from combined photovoltaics, wind energy and secondary hydroelectricity supply in Brazil. *Solar Energy* 78 (5), 670–677.
- Danish Energy Agency, 2001. Rapport fra Arbejdsgruppen om Kraftvarme- og VE-Elektricitet (Report from the Expertgroup on CHP- and RES-Electricity). Danish Energy Agency, Copenhagen.
- Danish Government, 1996. Energy 21, The Danish Government’s Action Plan for Energy. Ministry of Environment and Energy, Copenhagen.
- Duic, N., Alves, L.M., Chen, F., Carvalho, M.D., 2003. Potential of kyoto protocol clean development mechanism in transfer of clean energy technologies to

- Small Island developing states: case study of Cape Verde. *Renewable & Sustainable Energy Reviews* 7 (1), 83–98.
- Duic, N., Juretic, F., Zeljko, M., Bogdan, Z., 2005. Croatia energy planning and Kyoto Protocol. *Energy Policy* 33 (8), 1003–1010.
- Gross, R., 2004. Technologies and innovation for system change in the UK: status, prospects and system requirements of some leading renewable energy options. *Energy Policy* 32 (17), 1905–1919.
- Hvelplund, F., Lund, H., 1998. Rebuilding without restructuring the energy system in east Germany. *Energy Policy* 26 (7), 535–546.
- Kempton, W., Kubo, T., 2000. Electric-drive vehicles for peak power in Japan. *Energy Policy* 28 (1), 9–18.
- Kempton, W., Letendre, S.E., 1997. Electric vehicles as a new power source for electric utilities. *Transportation Research Part D: Transport and Environment* 2 (3), 157–175.
- Kempton, W., Tomic, J., 2005a. Vehicle-to-grid power fundamentals: calculating capacity and net revenue. *Journal of Power Sources* 144 (1), 268–279.
- Kempton, W., Tomic, J., 2005b. Vehicle-to-grid power implementation: from stabilizing the grid to supporting large-scale renewable energy. *Journal of Power Sources* 144 (1), 280–294.
- Kempton, W., Tomic, J., Letendre, S., Brooks, A., Lipman, T., 2001. Vehicle-to-grid power: battery, hybrid and fuel cell vehicles as resources for distributed electric power in California. Davis, CA: Institute of Transportation Studies Report # IUCD-ITS-RR 01-03.
- Kempton, W., Archer, A., Garvine, R., Dhanju, A., Jacobson, M., 2007. Large CO₂ reductions via offshore wind power matched to inherent storage in energy end-uses. *Geophysical Research Letters* 34 (L02817).
- Lund, H., 1999. A green energy plan for Denmark—job creation as a strategy to implement both economic growth and a CO₂ reduction. *Environmental & Resource Economics* 14 (3), 431–439.
- Lund, H., 2000. Choice awareness: the development of technological and institutional choice in the public debate of Danish energy planning. *Journal of Environmental Policy & Planning* 2 (3), 249–259.
- Lund, H., 2003. Excess electricity diagrams and the integration of renewable energy. *International Journal of Sustainable Energy* 23 (4), 149–156.
- Lund, H., 2007a. EnergyPLAN Advanced Energy System Analysis Model. Aalborg University, <www.energyPLAN.eu>, Denmark.
- Lund, H., 2007b. Renewable energy strategies for sustainable development. *Energy* 32 (6), 912–919.
- Lund, H., Andersen, A.N., 2005. Optimal designs of small CHP plants in a market with fluctuating electricity prices. *Energy Conversion and Management* 46 (6), 893–904.
- Lund, H., Hvelplund, F., 1997. Does environmental impact assessment really support technological change? Analyzing alternatives to coal-fired power stations in Denmark. *Environmental Impact Assessment Review* 17 (5), 357–370.
- Lund, H., Münster, E., 2001. AAU's analyser (Aalborg University Analyses). In: Danish Energy Agency (Ed.), Bilagsrapport fra arbejdsgruppen om kraftvarme- og VE-elektricitet (Attachment report from the expertgroup on CHP- and RES-electricity). Danish Energy Agency, Copenhagen, pp. 35–50.
- Lund, H., Münster, E., 2003a. Management of surplus electricity-production from a fluctuating renewable-energy source. *Applied Energy* 76 (1–3), 65–74.
- Lund, H., Münster, E., 2003b. Modelling of energy systems with a high percentage of CHP and wind power. *Renewable Energy* 28 (14), 2179–2193.
- Lund, H., Münster, E., 2006. Integrated transportation and energy sector CO₂ emission control strategies. *Transport Policy* 13 (5), 426–433.
- Lund, H., Ostergaard, P.A., 2000. Electric grid and heat planning scenarios with centralised and distributed sources of conventional, CHP and wind generation. *Energy* 25 (4), 299–312.
- Lund, H., Hvelplund, F., Kass, I., Dukalskis, E., Blumberga, D., 1999. District heating and market economy in Latvia. *Energy* 24 (7), 549–559.
- Lund, H., Hvelplund, F., Ingermann, K., Kask, U., 2000. Estonian energy system—proposals for the implementation of a cogeneration strategy. *Energy Policy* 28 (10), 729–736.
- Lund, H., Hvelplund, F., Nunthavorakarn, S., 2003. Feasibility of a 1400 MW coal-fired power-plant in Thailand. *Applied Energy* 76 (1–3), 55–64.
- Lund, H., Siupsinskas, G., Martinaitis, V., 2005. Implementation strategy for small CHP-plants in a competitive market: the case of Lithuania. *Applied Energy* 82 (3), 214–227.
- Maeng, H., Lund, H., Hvelplund, F., 1999. Biogas plants in Denmark: technological and economic developments. *Applied Energy* 64 (1–4), 195–206.
- Mathiesen, B.V., Lund, H., Nørgaard, P., 2008. Integrated transport and renewable energy systems. *Utilities Policy* 16 (2), 107–116.
- Mathiesen, B.V., Lund, H., 2007. Energy system analysis of fuel cells and distributed generation. In: *Fuel Cell and Distributed Generation*. red./Francisco Jurado Melguizo. Kerala, India : Research Signpost, pp. 111–127.
- Münster, M., 2007. Use of waste for heat, electricity and transport—challenges when performing energy system analysis. In: *Proceedings from the Fourth Dubrovnik Conference on Sustainable Development of Energy, Water and Environment Systems*. Dubrovnik, Croatia.
- Short, W., Denholm, P., 2006. Preliminary assessment of plug-in hybrid electric vehicles on wind energy markets. NREL Report no.TP-620-39729.
- Toke, D., 2005. Explaining wind power planning outcomes: some findings from a study in England and Wales. *Energy Policy* 33 (12), 1527–1539.
- Tomic, J., Kempton, W., 2007. Using fleets of electric-drive vehicles for grid support. *Journal of Power Sources* 168 (2), 459–468.
- USDepartment of Transportation, 2003. Statistics, NHTS 2001 Highlights Report, BTS03-05. Bureau of Transportation, Washington, DC.
- Williams, B.D., Kurani, K.S., 2006. Estimating the early household market for light-duty hydrogen-fuel-cell vehicles and other “Mobile Energy” innovations in California: a constraints analysis. *Journal of Power Sources* 160 (1), 446–453.
- Williams, B.D., Kurani, K.S., 2007. Commercializing light-duty plug-in/plug-out hydrogen-fuel-cell vehicles: “Mobile Electricity” technologies and opportunities. *Journal of Power Sources* 166 (2), 549–566.