

**THE PLUG-IN HYBRID ELECTRIC VEHICLE, for PETROLEUM
DISPLACEMENT, REDUCTION OF CO₂, ELECTRIC GRID ECONOMICS,-
SYSTEM IMPLICATIONS and DIRECT USE OF RENEWABLE ENERGY**

by

Prof. Andrew A. Frank Dept. MAE

The Univ. of California-Davis, One Shields ave. Davis Ca.95616

Phone 530 752 8120, email aafrank@ucdavis.edu

and

CTO Efficient Drivetrains Incorporated, EDI

ABSTRACT

The Plug-In Hybrid Electric Vehicle, PHEV, can be designed to drive on electricity alone for the first 60 miles or 100 km per day before the gasoline engine is used to maintain the batteries and the driving load [4]. This kind of vehicle will be designed to use energy from conventional electric plugs with Ground Fault Interruption, GFI. If the electricity is generated by Solar or Wind the cost can be paid for by the displaced gasoline use by the PHEV compared to a conventional gasoline vehicle in about 3 to 4 years. This implies that the cost of “fuel” for the PHEV will be **zero**. The important feature of the PHEV is that it can be done today without the need for an infrastructure by using the existing electric grid and the existing gasoline stations. This paper will discuss the economics of the PHEV and its’ application to our society with the benefits of enhanced lifestyle, “0” CO₂ with very little investment. The use of the PHEV to enhance the existing electric generation system and the possibility of the electric company providing almost free electricity to the PHEV and still be financially positive using the concept of Vehicle to Grid, V2G will be explained

Key words: “Plug-In Hybrid Electric Vehicle”, ”global warming”, “vehicle to grid”

1. Introduction

The world is reaching a crisis in carbon emissions into the atmosphere at the same time it is beginning to reach a limit in the amount of oil that can be produced in any year. These two events are causing the world to look for solutions that will begin to reverse these effects now since the world is beginning to realize that proceeding into the future without change will result in the destruction of the earth as we know it. We will put the earth back to the way it was 500 millions years ago when the earth had primarily a CO₂

atmosphere and life forms were extremely simple. Or another way to put it, all the familiar life forms we are accustomed to will be replaced by forms we don't understand. This fact is beginning to be considered most seriously by most of the scientific community. It is caused by the **combustion** of fossil hydrocarbon materials sequestered in the earth for 100 to 500 million years to create work energy and heat for our society.

But few alternative solutions have been proposed to create energy for human use. The way to change this is to stop fossil fuel combustion as a way to generate heat and create work energy. The question is only what do we replace fossil combustion with?

This paper will show that we can replace fossil combustion for creation of useful energy by renewably generated electricity to provide everything that is used by humans today without having to change our lifestyle and cost less than what we currently pay for energy by using solar and wind directly. The cornerstone for this transition will be the newly discovered concept, the Plug-In Hybrid Electric Vehicle, PHEV.

The PHEV is finally coming to the general public's eye. It is a concept that has been promoted by the author and a few researchers in Universities for about 30 years and largely ignored by the major industries, and scientist around the world [1]. The reason for this was the promotion of long term concepts that will allow the current industry in energy production and vehicles to continue its' current business without change until they are forced by the people (their customers) or government to change because the world is severely affected by the negative consequences of their actions causing global warming. Because of the numbers of the mechanical things that must be changed to have any world effect, we need to attack the problem of changing the mass volume of machines that are creating the problem quickly world wide.

Automobiles and trucks are the machines that can be used to change the way we do things. We can turn them into PHEV's as the media to begin the energy transition without a change in the world's lifestyle, the manufacturing or the energy infrastructure. For the third world who aspire to become as affluent and comfortable as the first world they can leapfrog the first world by going directly to a zero fossil combustion society

The PHEV concept will allow all modern society to gradually move to a greener and sustainable society by providing a more affluent way of life world wide while at the same time restore our biosphere to the one that can support the diversity of life we currently know and allow the world to move toward future millennia in a sustainable fashion.

Then what is a PHEV and how can this technology be so comprehensive?? The PHEV is a way of transporting people with the capability of using electric energy generated by systems that have a cycle time from generation to use of one year or less. But, we must start from the current way of life we have constructed for ourselves which is electricity generated by fossil fuels, nuclear, water, a little wind, some liquid fuels derived from oil and a lot of Natural Gas.

Thus it is the objective of this paper to show that we can transition today to a completely sustainable energy society with no sacrifices in performance and at an incremental cost that will pay back in less than a few years and ultimately end up with almost zero energy costs.

This PHEV concept has been around for the last 30 years but some of the technologies that will make it match the cost of conventional cars had not yet been fully developed. In the last few years the price of energy has risen and critical technology has been developed so that now a cross over of costs is occurring and the PHEV is now beginning to show costs lower than the current cost of energy. This cost differential will continue to increase as time goes on for the next 30 to 50 years so that the PHEV and its ability to integrate society's energy use will become more compelling as time goes on.

2. The PHEV xx (xx indicates the All Electric Range, AER, in miles)

The PHEV is simply a hybrid electric vehicle with a **much smaller and lower powered engine** and a much **larger power electric motor and battery** system than a conventional hybrid. Then the large battery system, which also has larger energy storage capability, does not depend on the engine for a full charge but rather only to maintain the charge. The large energy capability of the battery is then capable of accepting electric energy from off board sources. In addition, PHEV battery has the capability to feed energy from the vehicle to other off board stationary uses. Four representative vehicles constructed at the University of California at Davis are shown below. These vehicles have the same power and better performance than the current conventional vehicles but weigh no more!!

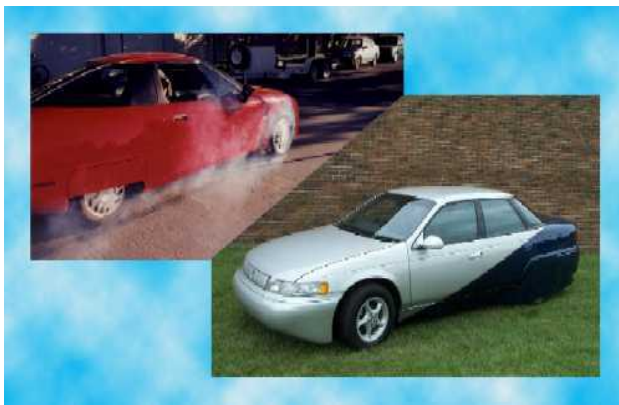

EVI converted to PHEV 80
80 mpg and high performance
2002

Mercury Sable to PHEV 60
58 mpg city-highway 1998



Chevrolet Suburban PHEV 60
28 mpg city-highway 2001

Figure 1 Photos of prototype PHEV;s constructed at UCDAvis

Main Components of a 2 ton Chevrolet Equinox PHEV 40

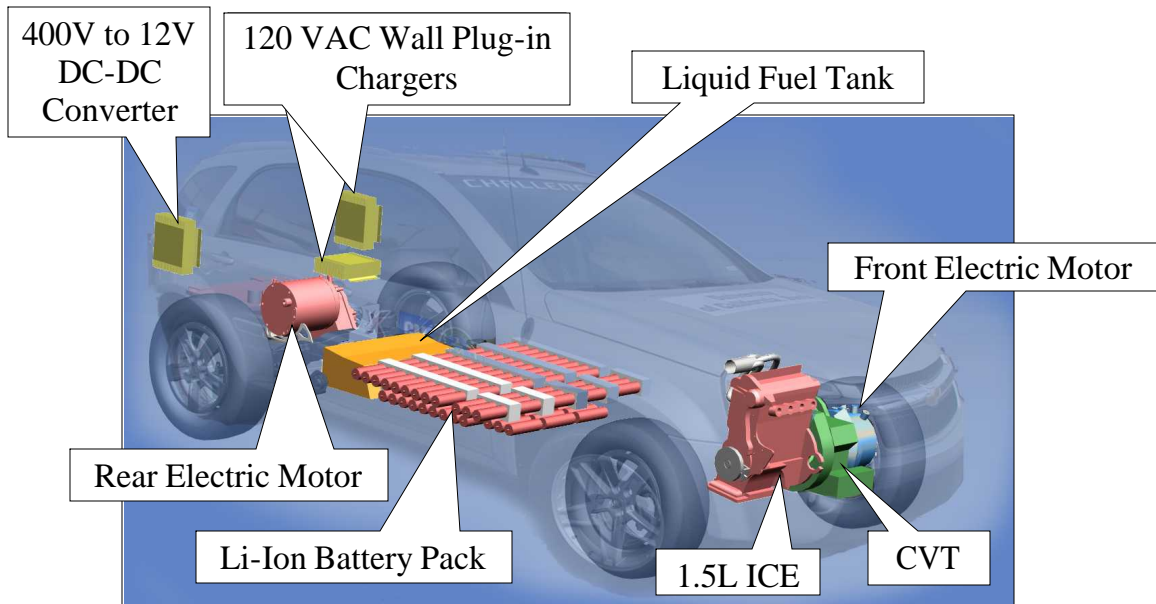

Figure 2. The Plug-In Hybrid Electric Vehicle, PHEV 40 Chevrolet Equinox conversion and Components.

This concept has the following features:

1. Performance better than the conventional vehicle.
2. Provide much better fuel economy when using only liquid fuel
3. Weigh no more than the conventional car regardless of All Electric Range AER.
4. AER capable from 20 miles (30km) to 60 miles (100km) all at the same weight using current batteries
5. Use as much off board Electric energy as possible (up to 90% or more).

3. The New Requirement for Automotive Vehicles is no longer simply emissions but Petroleum and Coal (P/C) Displacement.

This P/C displacement can only be done by **renewable** electricity that is generated by solar and wind and renewable liquid fuel created by biomass generated in a one year cycle. P/C is created from solar energy generated over a cycle time of 100 to 500 million years or more. This means that the carbon was absorbed from the atmosphere by plant material and stored in the earth. We are liberating the carbon sequestered over the last 500 million years by **combustion** in a very short time. Less than 100 years.

The earth will be put back to the way it was 500 million years ago when a completely different life form was sustained. We as a species cannot adapt that fast and we will

simply disappear with great negative consequences unless we begin to shift our society world wide now. We have but a few years to do this.

The PHEV will allow us to eventually move to zero fossil fuel CO₂ Emissions. The following chart shows how all classes of vehicles from the large SUV to the compact car configured as a PHEV will create CO₂ using the existing electric and gasoline infrastructure.

**Greenhouse Gas Emissions for all light duty cars & trucks—
from conventional vehicles to hybrids to plug-in hybrids.**

Note PHEV with Solar & bio-fuel provides “0” CO₂!!

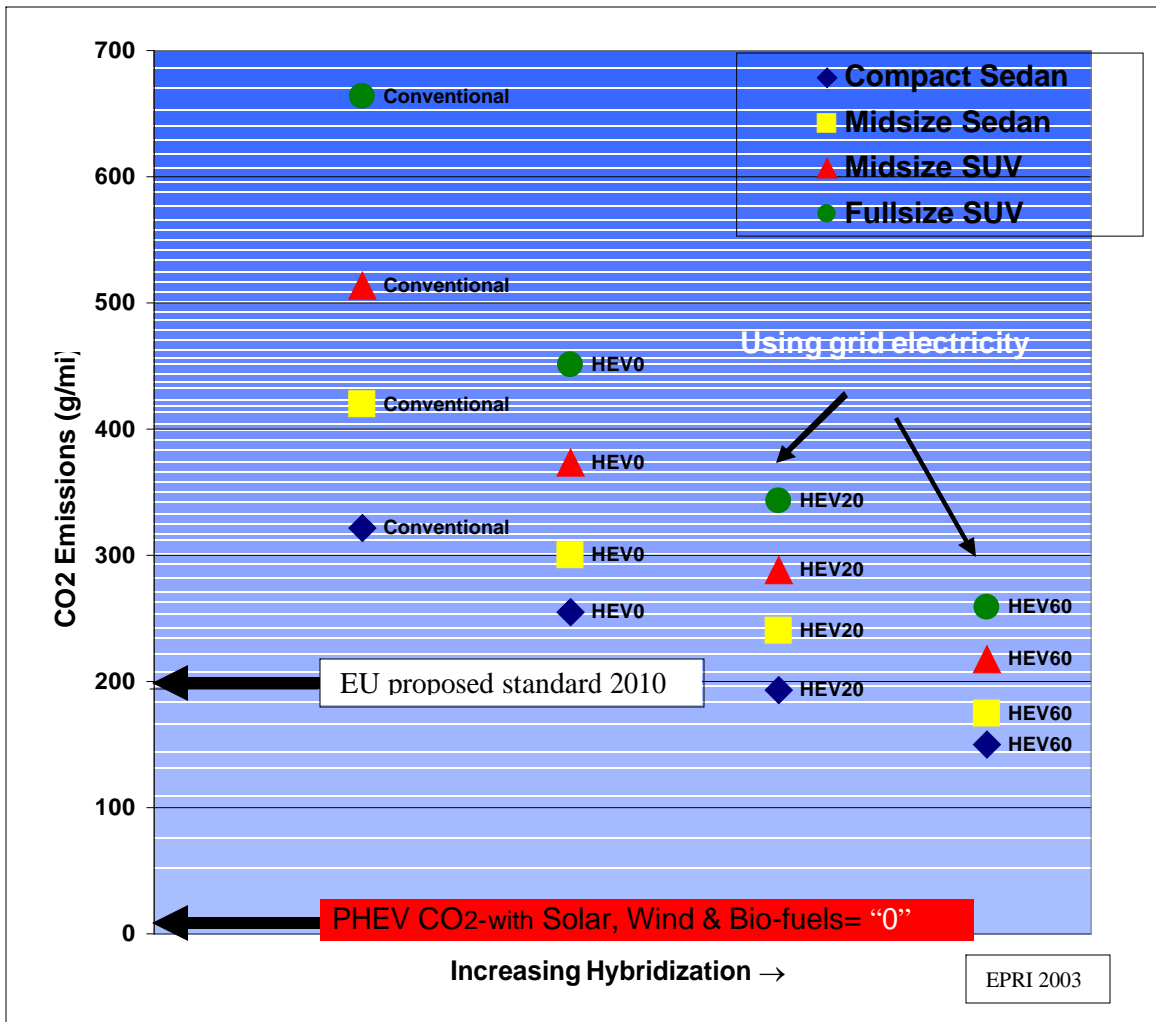

Figure 3. CO₂ emissions from all classes of light duty vehicles, from conventional to PHEV and from compact sedans to full size SUV’s

This chart shows that the PHEV using conventional gasoline and today’s grid will reduce CO₂ emissions by more than 2 and this can happen today. The chart also indicates that the Mid size SUV and sedans all meet the proposed EU CO₂ standards for 2010 if the

vehicle has a 60 mile or 100 km AER. But in Red, the CO₂ emissions can be essentially reduced to zero in a PHEV because the liquid fuel can be ethanol which can be essentially carbon neutral since the ethanol from cellulous will be from plants that need CO₂ for re-growth. This is possible because the PHEV uses only 10% liquid fuel.

This all means that the PHEV will allow us to transition from our current fossil fuel CO₂ emitting society to a zero CO₂ emitting society simply by adding solar and wind renewable electricity. This is a simple way to accomplish Zero Carbon Dioxide with no sacrifice in life style. In fact, the cost of transportation will be reduced because the cost of fuel generated from solar electricity is much less than gasoline today, using the PHEV.

For example the cost of solar electricity has been calculated to be about 15 cents a kwhr. The cars that we have constructed use about 0.25 kwhr per mile on electricity alone. Or the cost is less than about 4 cents a mile. But an identical conventional car getting 25 miles per gallon at \$3.00 per gallon gasoline will cost about 12 cents per mile for fuel. Thus using solar electricity for driving is less than ¼ the cost of gasoline today. Electricity from the grid is lower cost but it is not from renewable sources now except the little generated by water and wind. Nuclear sources are more or less zero carbon but it is not a renewable source and it's cycle time for regeneration is even longer than fossil fuel.

4. Cost of Implementing a zero Carbon non-fossil fuel combustion Energy System.

To answer the question of how we can begin to eliminate the use of combustion to create energy and the costs involved, we have to introduce concepts not well understood by industry, the public and government.

The social sectors that are using energy are 1.houses, 2.transportation, and 3.industry. We will show that the cost of shifting to a non-combustion society now will result in **lower** cost than the current fossil fuel combustion society.

This vision that we are proposing is based on research and experiments constructed over the last 35 years [7]. The corner stone of the concept is **Electric Energy Storage** and not generation. This will be done by a large number of electric storage batteries, that we propose, will be distributed throughout our future society. The key is that we must be able to **transition** from the combustion society we currently have to a non-combustion society in a **seamless** fashion. We will present a vision that will begin by using our society as it is constructed with our current road system, our homes, our industry and our automobiles. Our vehicles already have batteries in our cars distributed in our society but they are too small to do what we want.

The only way we can do this is to have the cost of such a transition no more than what we are currently expending to support our current lifestyle, but we will show that we will end up with a more comfortable and affluent society in the near future. The proposed PHEV will provide the energy storage we need but what about the cost??

The cost of the PHEV vehicles shown has been estimated by the USDOE, EPRI, and Car companies to be only slightly (about 20% to 50%) above the current cost of today's automobiles.[EPRI [7] 2003]. This estimate was done over 4 years ago and since then newer technology in batteries have evolved which make the estimates high. To put this in perspective the cost of a PHEV with about 40 to 60 miles of all electric range is about equivalent to a sun roof, deluxe interior with leather seats, performance package, fancy wheels and a navigation system for a new car today.

Now let us examine some of the benefits that the PHEV can provide the user to offset this incremental first cost:

1. The PHEV has enough energy stored to power your house for 24 hours or more, including air conditioning.
2. It can provide power back to the house and grid as well as take power from the house and grid.
3. In addition, if the house has about 300 square feet of solar panels on the roof then the panels can provide energy for both the car and the house on a daily basis.
4. The PHEV system can always be backed up by the conventional grid and gas stations on cloudy days.
5. It provides the individual a back up for the grid as well during storms and other potential natural disasters. Thus providing the PHEV owner **Energy Independence**.
6. Heat storage is another matter and will not be addressed here but in another paper. It could also be generated by solar and wind and stored in mass.

The cost of using electricity to drive in these PHEV cars at the current national average of 10 Cents/kwh is equivalent to buying gasoline for the PHEV at 70 cents per gallon. And if solar is used for 30 years it is equivalent to about 20cents a gallon of gasoline for the PHEV. Thus, the initial up front cost of solar can be paid off in the near future today by the cost of the displaced gasoline. And as the price of gasoline rises the pay back period for solar becomes shorter. But once the solar panel is paid back by gasoline savings the energy for driving become **free** for about the next 25 years!! The following photo shows our latest PHEV40 being charged by about 200 square feet of solar panels. Today's sun will give you tomorrow's driving!!



Figure 4. Solar charged SUV

The cost of electric energy from the grid can be even lowered by the mass introduction of the PHEV since the current grid electric price includes the cost of supplying power in the day and night. The demand for electric power at night is only about 1/2 to 2/3 the power needed in the middle of the afternoon. But the current grid has no way to store electric energy. So it is necessary to turn on temporary power plants in the middle of the day, making the cost of electric energy high due to idle plants. In addition some of these plants have to be left on but idling most of the day (spinning reserves). This equipment and system make for the current cost of electricity at 10 cents/kwhr. If we had about 30% to 50% of our vehicle fleet with PHEV's with 30 to 60 miles of All Electric Range, AER, and we had an intelligently controlled grid, with energy back to the grid, V2G, we could eliminate the spinning reserves and the peaking plants thus lowering the cost of electric energy generation for everyone. This could be as low as buying the equivalent gasoline for the conventional vehicle at about 50cents/gal or less!! Or it means the entire grid electricity charges could be reduced by 20% or 30%.

This offset in running cost and lower maintenance cost due to mechanical simplicity must also be factored into the cost of changing from a fossil fuel combustion society to the non- fossil fuel combustion society we are discussing.

With the current price of gasoline, these factors will provide a lower cost for the non-combustion society. If we factor in the inevitable rise in gasoline prices due to the peak in oil production that will or has already occurred, the cost of the PHEV zero fossil fuel combustion society is even lower. Thus the cost could be lower than the cost of our current transportation but with no sacrifice in performance or utility.

5. Societal Benefits of the PHEV

The PHEV is an individually and privately owned vehicle. The addition of a personal solar system is individual. But if the PHEV and personal solar and wind are adopted by millions of people in the country we will have accomplished a real movement toward nationwide energy independence. This is the fastest way to get the world out of the fossil fuel combustion society!! It however means world wide introduction of the PHEV and the adoption of private and personal solar and wind.

To achieve this level of penetration (50%) of the PHEV and solar and wind systems may be a 20 to 30 year process but if we can begin the introduction of the PHEV with solar systems now we can begin to offset the inevitable increase in oil and coal prices while improving our lifestyle.

It is important to realize that the **central** electric power generation and grid system cannot be eliminated but they **must grow** with an ever increasing portfolio of change from fossil fuel combustion and Nuclear to renewable electricity and bio-fuel. But **central** solar and wind generation distributed by main power lines will still also be needed. To make these systems work with a high penetration of renewable power generation in the power portfolio, **energy storage** systems are necessary. The PHEV with Vehicle to the grid

capability, V2G, can again be the needed piece of the equation. Just like the above where the PHEV was used to provide a leveling of the grid and provide energy for the home, this can be looked at from the central power plant perspective as well. To make this system work however, the power companies must be in control of charging or discharging every vehicle's battery plugged into the grid in society. And we must have an even more intelligent centrally controlled grid. Some of the hardware and software for this system does exist now, but much more will have to be developed as the need arises over the next 20 to 30 years. In the future, the grid will need to be much more automatic than it is today since the current grid is demand driven and with a lot of human control. But in the future with a large or mostly renewable portfolio of energy generation schemes and distributed PHEV's all over society storing energy, intelligent control of the energy flow with knowledge of the location and quality of each vehicle's battery and the state of all the electric generators, including the home solar and wind systems, will be necessary to make the proper intelligent decision at every moment in time. So the central power command system will have an ever more important job of coordinating a much more complex system. The main point is that this system is all computer controlled and could be even simpler to control from the human operator point of view.

6. PHEV and Solar-Wind Evolution and Change in Social Structure Time Frame

With the introduction of the PHEV concept and the possibility of supplying our entire personal energy needs renewably, we can estimate the time of introduction dependent on new car PHEV sales penetration. The following estimated time frame could result.

PHEV Renewable Energy Society Evolution Time Frame (non fossil fuel combustion)

Years into the future	% stationary Renewable Energy	Home	School & shopping malls	Work place & industry	% penetration transportation PHEV's
10	5% -10%	Solar/wind			1%-5%
20	20%-30%	Solar/wind	Solar/wind		50%-60%
40	80% +	Solar/wind	Solar/wind	Solar/wind	90%+

Resulting Social Structure

1. Energy ---- 1/10 to 1/4 current costs of energy and much less fossil fuel.
2. Affluence increased due to lower energy costs
3. More jobs distributed into society
4. Much higher energy stability
5. Individual energy independence
6. Zero fossil fuel carbon foot print

7. Implications for the Electric grid.

The grid can be balanced by having the batteries charged when there is excess power. This can be done automatically by the grid giving energy to the PHEV when it has excess energy available on a second by second basis. The PHEV should be plugged in at all times it is parked. Since a typical car is driven only about 3 hrs a day it could be plugged in for 21 hours a day. But during the time it is plugged in the utility grid may or may not supply charge at any instant in time. It will depend on the demand placed on the grid at any moment. It may be that at one instant in time the grid has excess power then particular PHEV's will be charged. But the grid will decide whom to charge and whom not to charge and when. This can be done simply by turning a particular port on or off. Thus the grid will have demand control for distribution of energy. This will allow it to level load if enough PHEV cars are parked. The objective is to have millions of cars parked and plugged in distributed all over the city but capable of accepting or supplying only 1.5 kw. Each car will have its' battery assessed by the grid with the following information:

1. The type of car and make and model and age and miles.
2. The type of battery, chemistry and age, OEM or replacement
3. The battery history over the last 24 hours and current state of charge (SOC)
4. The battery temperature and history over the last 7 days.
5. The SOC history from birth to now.
6. Driver or owner desires today and on the average.
7. Additional information

The grid then can decide on which car to charge at 1 second intervals and how long to keep the charger on. The car Battery Monitor System BMS will monitor what is going on and may decide to stop charge at any time if it determines the battery has received enough charge for the moment. We feel that the grid computer and the car computer must be "on" at all times to monitor the State of the batteries and be in continuous communication once it is connected. Thus as soon as the vehicle is plugged into an electrical receptacle, the entire grid control system becomes active and the state of the batteries will be determined to decide what can be done and what is needed. The "State" includes SOC, temperature, history etc as stated above.

This strategy allows the PHEV's from any manufacturer and any known battery chemistry to be charged under control and never have to worry about over charge or being put into a dangerous uncontrolled situation. The data for the batteries will be furnished to the grid computer when the vehicle is registered with the grid with a proper ID. If the data is not correct or missing the charger ready light simply does not come "on" and no electric charge will be provided.

8. Power Company Mix issues.

One of the problems is the power generation mix we have in this country. Some generators are private, some are public and some are public/private with various types of control. What is needed is to find common rules that can be applied to all energy sources. These rules are needed to ferret out what may happen if a vehicle is charged in one district but feeds power back to another district. We do not feel this is a problem because the energy feed from any one vehicle is only a few kWhrs at most. The important thing is that the overall grid will become more efficient with much less use of the main power lines since energy is circulated only at the substation level. This means each utility that is signed up will benefit from the system regardless of where the energy came from. In fact, local privately owned solar may be worked into the system simply by running the electric meter backward. Then the cost of the system is simply trading energy with no need for physical paper billings, the PHEV user may actually be receiving “free” charge most of the time. Of course it is not exactly free since the batteries are receiving or providing energy cyclically exercising the life of the battery. No matter what however the BMS system should be designed to provide over 150,000 miles and 15 years.

9. The Central power energy management system

The grid control should have a tree structure of computers. There will be a central computer, a computer at the substations, a microprocessor controller at each plug with a communication system for all the computers talking with each other. In addition the vehicle battery data is also communicated across the plug and the plug’s microprocessor.

This structure is illustrated in Figure 5 where the green lines represent communications and the orange line represents power at 1.5 kw. Thus the only decision is whether to send power to or from the battery pack or do nothing. Thus the plug microprocessor is extremely simple and can easily be a \$10 device. The objective is to have a very low cost device that can be manufactured in high volume and be readily available in the local hardware store. Each substation will be limited to about 1000 ports. And each main line may have 1000 substations. Thus there could be 1 million vehicles being controlled by a Main line.

Thus at 1.5 kw at each plug or vehicle the main line can control energy back and forth to the grid up to 1500 megawatts every second at a resolution of 1.5 kw. This is enough to more than take care of spinning reserves and power management for most cities. Of course, each main line can be expanded simply if needed. The current power management systems may be eventually automated. To make such a system work at full capacity, however, requires millions of PHEV’s or EV’s.

The main point is that the system can begin from our current system and grow gradually toward the fully automated system as the number of vehicles grow in the system. The current system can be used for a long time into the future and a transition point can be decided by the grid operators when they decide to begin to introduce the computer controllers. The current grid regulation scheme can be used for many years into the future but we should be planning now for the eventual arrival of millions of PHEV's.

The PHEV control system is diagrammatically illustrated below with Figure 5..

The system can also be integrated with local and centrally generated solar and wind since each car system represents a storage media that can be used by the electrical system. The important thing is that the main grid computer is in complete control to manage the entire system. Of course this system has to have the reliability of an aircraft traffic manager to prevent failure but that technology is available now.

The programming of this system is not currently developed but it can be developed and tested on pilot projects long before it is tried in the main systems. Such pilot projects need to be done on relatively small utility grids, such as the utility grid of an electric transit system like the Bay Area Rapid Transit, BART, system. This system has cars which drive in and park at the station daily and it contracts for power two or three years in advance. Meaning it must predict instantaneous power use. Since this cannot be done perfectly BART will pay for peak charges and will contract for excess electricity that it cannot use.

We calculate that it is possible to save both the BART system \$2 million in peak charges and let the PHEV's or EV's plugged in at the station have **free** charge. This cost needs to be factored into the up front cost of the PHEV since it is like having a car with free gasoline for life!!

This means that the incremental cost of the PHEV stated above when integrated with the Electric power system could have almost no cost for the energy or "Fuel" if we keep the cost of electricity the same throughout society. The reason this can occur is that the PHEV with V2G distributed in society with millions of vehicles can essentially eliminate the need for peaking plants and spinning reserve plants. This savings is then used to provide energy to the PHEV user.

The other way is to reduce the cost of electric energy to everyone and charge the PHEV user the same cost as everyone. Then the cost per mile of operating the PHEV will still be equivalent to about buying gasoline at 50cents a gallon for the PHEV using electricity.

This kind of economics then drives the demand for longer All Electric Range, AER PHEV's. The current thinking in the industry is to only supply the public an AER of 10 to 20 miles. We think this is incorrect since with such a low AER the batteries have to be much more robust in Cycling and the power density needs to be higher. Using a 60 mile or 100km AER the batteries are treated much lighter and the daily Depth of Discharge DOD is less on the average. These factors lead to much longer life.

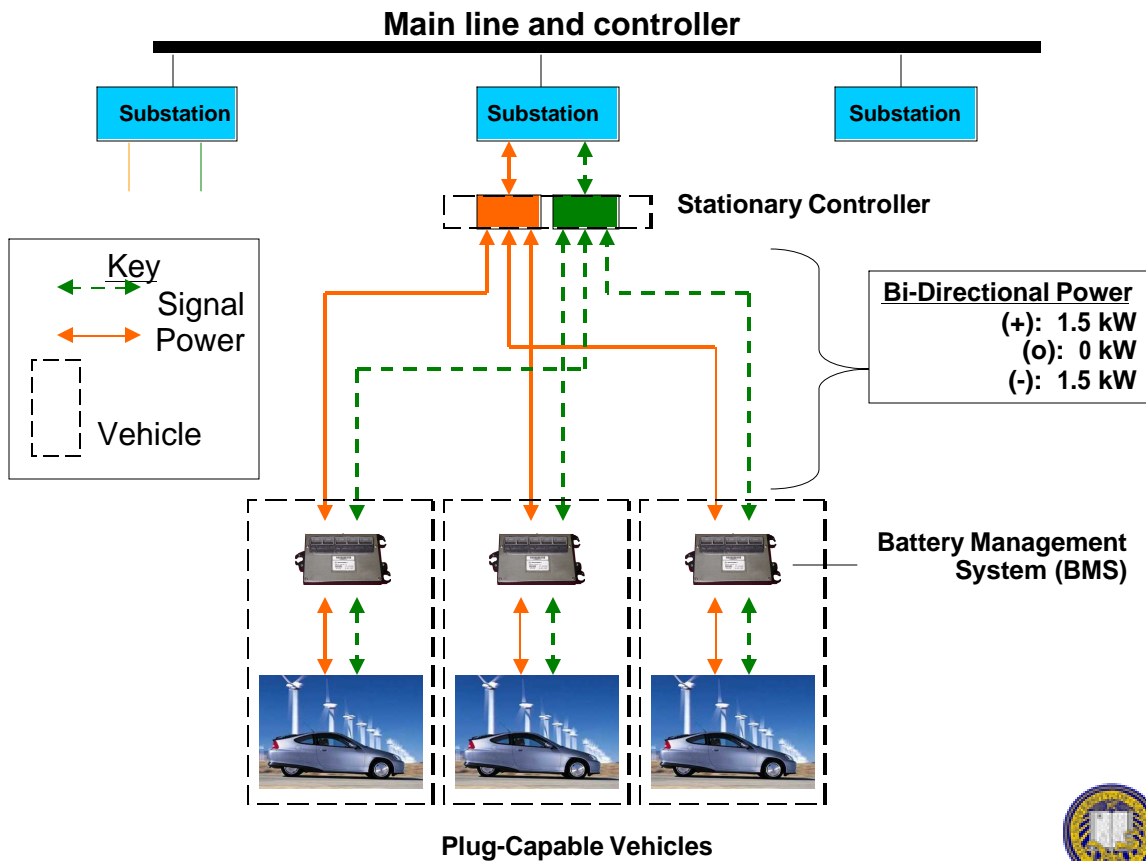

Figure 5. A diagram of the vehicle bidirectional charging system.

10, Conclusions

We have presented the concept of the PHEV and how it can be integrated into our current society offsetting the need for Peaking and Spinning Reserve Electric Plants and reducing the cost of electricity for everyone. Or if not reducing the cost then providing the PHEV or EV with a BMS and the proper equipment in the grid for V2G with free energy! This is possible since the Grid is reducing the need for peaking and rolling reserve plants.

A study of the local Sacramento area power grid and assuming 20 percent of the cars in the area are PHEV with the capability of being controlled by the grid with the control system discussed the following figure presents the consequences.

The PHEV can be used to **balance the Electric Grid ---Integrating electric power and transportation energy**

There's enough generating power for 80% of the vehicle fleet with no more new power plants!! The peaking plants could be turned into base load plants-----This could take 20 years of PHEV growth before this volume is achieved!! Shown below is the result of 20% penetration PHEV of the total car population in Sacramento CA.

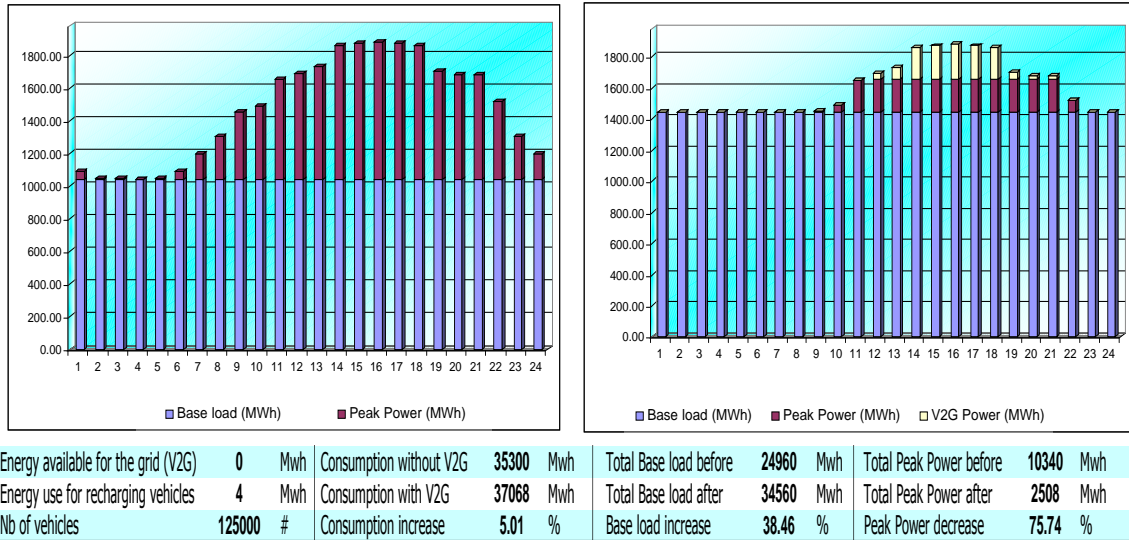

Figure 6. The Sacramento power grid use today for 24 hours on the left. The same grid with 20% of the cars in the area converted to PHEV and charged with an intelligent grid with each car fitted with a bi-directional 1.5 kw charger to enable V2G

Notice the chart on the right has the cars charged at night and the cars provide a little energy back during the day. The amount of charge provided at night can be much more than provided back in the middle of the day. This proportion can be set by the grid controller to say take no more than 10% of what was provided at night. If this is the rule then this results in some of the vehicles providing the white peak of energy in the right hand chart.

The result is that the peaking loads are reduced from about 80,000 mw to 10,000 mw. Or the closing down of 7 out 8 peaking plants!! This saving in peaking plants means either the cost of electricity should be lowered for every one or the PHEV's should be receiving free electricity since it is providing a service to everyone. Obviously if there were more PHEV's like about 30% of the current cars in the area then the need for peaking plants go away completely.

With more PHEV's in society then we can begin to replace our base load plants with centrally generated wind and solar systems. Of course at the same time it should be

encouraged for people to purchase their own small 1 kw to 2 kw solar and wind generators so that they can become energy independent and not have to depend on the grid or the local gasoline stations. This provides added value that people will be willing to pay for now.

There are many 1 kw generators sold at the local hardware store for people to use as emergency power or for auxiliary use in outdoor activities etc. The 1.5 kw V2G charger from the PHEV big battery pack will supply enough energy for 1 or 2 days from the battery alone. When the battery runs to the minimum allowed the engine can be designed to come on automatically to recharge the battery for about an hour then shut off for another day.

Thus the PHEV has much more value than just a vehicle to provide transportation. It can provide lower cost electricity for everyone or can be paid for by the use of it's battery to balance the load. It should be pointed out that the V2G concept and the intelligent charge concept should be implemented on a second by second basis and not on a hourly or daily basis as is currently done in Power system control. This gives the grid much tighter control in the long run, a much more efficient electric distribution system.

Finally it was shown that the system can be integrated with Central Solar and Wind as well as with local privately owned solar and wind. In addition it is suggested that the shuttling of energy be done in a controlled manner so that no money need be transferred, but rather on energy is traded. And the payment to the PHEV owner for the use of his battery is simply more charge by the end of the day. Obviously there may be days the PHEV will have more or less charge from the grid. This is not a problem for the PHEV since the amount of electricity difference from day to day may only be the equivalent of about ¼ of gallon of gasoline.

Thus the PHEV provides the best possible course of action to transition our society from a fossil fuel burning society to a renewable energy society without any sacrifice in performance or utility of our current lifestyle. In fact our lifestyle will be improved since we will be paying much less for energy!!

Now what should we do with the oil production and coal production machinery that we have invested in?? It is obvious that we cannot shut done these segments of our society immediately without a major disruption. In fact the fossil material is very valuable for other uses than combustion!! For example, making plastics that are recyclable. Thus instead of burning the Fossil material in coal and oil, we should be turning the material into plastics that can be used in our society forever by recycling. Our new society could be constructing houses from plastic 2x4's instead of using wood from forests. These materials will withstand insects and dry rot and should last much longer than wood products and be cheaper. And they may well be stronger and more structurally stable. We could manufacture paper as well from coal and oil.

This shift in our use of materials will keep our industry going as we transition to this zero CO₂ society without putting millions of people out of work!! The auto industry will also

profit from the PHEV since it is a new product that will be salable to the general public with expanded product utility since it is integrated with stationary energy use.

The objective is to transform society in a smooth controlled fashion from our current fossil fuel dependency to a fully renewable and sustainable CO₂ free society with no disruption seamlessly. This can only be done with the mass introduction of the PHEV everywhere in the world at the same time..

Thus our current goal is to try to provide the technology to world wide industry so that the PHEV can be mass manufactured everywhere as quickly as possible before global warming and our atmosphere becomes unsustainable to our species.

References.

- [1] A.A. Frank, “The Advantages of the Next Evolution in Hybrid technology “the Plug-In Hybrid” University of Ca.-Davis, Davis, CA 2005.
- [2] A.B. Francisco, “ Implementation of an Ideal Operating Line Control Strategy for Hybrid Electric Vehicles”, in *Mechanical and Aeronautical Engineering*, Univ. of CA-Davis2002 page 109
- [3] J.M. Miller, *Propulsion Systems for Hybrid Vehicles*: The Institution of Electrical Engineers, 2004
- [4] N. Meyer, B.Huff, et al, and A. Frank “Design and Development of the UC Davis Future Truck (2000 Chevrolet Suburban)”, University of Ca-Davis, Davis , CA 2000
- [5] R. Schurhoff, “The development and Evaluation of an Optimal Powertrain Control Strategy for a Hybrid Electric Vehicle. In *Mechanical Engineering* , Davis, The Univ of Calif.
- [6] R. Saeks, C.J.Cox, “Design of an Adaptive Control System for a Hybrid Electric Vehicle”, in *IEEE International Conference on Systems, Man , and Cybernetics*, 1999
- [7] EPRI PHEV Consortium report “Exploring Hybrid Electric Vehicle Options” Published in 2002, Vol. 1, 2003 Vol.2 and Vol.3.



ANDREW A. FRANK --- Bio

Professor, Mechanical and Aeronautical Engineering MAE
University of California, Davis Davis, CA 95616-5294
CTO Efficient Drivetrains Inc.
B.S. (1955), University of California, Berkeley
M.S. (1958), University of California, Berkeley
M.S. (1965), University of Southern California
Ph.D. (1968), University of Southern California
Aerospace industry 14 years, Univ. Wisconsin, 18 years EE,
UC Davis 22 years MAE

email: aaf Frank@ucdavis.edu Phone: (530) 752-8120 FAX: (530) 752-4158

