



Design, demonstrations and sustainability impact assessments for plug-in hybrid electric vehicles

Thomas H. Bradley^{a,*}, Andrew A. Frank^b

^aWoodruff School of Mechanical Engineering, Georgia Institute of Technology, 801 Ferst Drive, Atlanta, GA 30332-0405, USA

^bDepartment of Mechanical and Aeronautical Engineering, University of California- Davis, One Shields Avenue, Davis, CA 95616-5294, USA

Received 16 April 2007; accepted 30 May 2007

Abstract

Plug-in hybrid electric vehicles (PHEVs) are hybrid electric vehicles that can draw and store energy from an electric grid to supply propulsive energy for the vehicle. This simple functional change to the conventional hybrid electric vehicle allows a plug-in hybrid to displace petroleum energy with multi-source electrical energy. This has important and generally beneficial impacts on transportation energy sector petroleum consumption, criteria emissions output, and carbon dioxide emissions, as well as on the performance and makeup of the electrical grid. PHEVs are seen as one of the most promising means to improve the near-term sustainability of the transportation and stationary energy sectors. This review presents the basic design considerations for PHEVs including vehicle architecture, energy management systems, drivetrain component function, energy storage tradeoffs and grid connections. The general design characteristics of PHEVs are derived from a summary of recent PHEV design studies and vehicle demonstrations. The sustainability impact of PHEVs is assessed from a review of recent studies and current research and development needs for PHEVs are proposed.

© 2007 Elsevier Ltd. All rights reserved.

Keywords: Hybrid electric vehicle; Battery; Sustainability; Carbon dioxide; Petroleum; Pollution; Electric grid

Contents

1. Introduction	2
2. PHEV design	2
2.1. Basic design considerations	2
2.1.1. Vehicle architecture.	2
2.1.2. Energy management	2
2.1.3. Drivetrain function and requirements	3
2.1.4. Energy storage system.	4
2.1.5. Grid connection	4
2.1.6. Other considerations	5
2.2. PHEV design studies	5
3. Vehicle demonstrations	6
3.1. Research vehicles	6
3.2. Original equipment manufacturer vehicles	6
4. Sustainability impacts	6
4.1. Petroleum consumption	7

*Corresponding author. Tel.: +1 404 685 9364; fax: +1 404 894 8336.

E-mail address: bradley@gatech.edu (T.H. Bradley).

4.2. Criteria emissions	8
4.3. Carbon emissions	9
4.4. Electric grid	10
5. Research needs for PHEVs.	10
6. Conclusions	11
References	11

1. Introduction

The personal transportation energy sector has been particularly resistant to diversification of its energy inputs toward more sustainable energy sources. In 2005, less than 1% of the 28 quads of energy in the US transportation energy sector came from renewable sources, primarily alcohol biofuels [1]. The dearth of non-petroleum energy sources for transportation is due, in part, to technical challenges, consumer requirements and the high-cost infrastructure dedicated to conventional petroleum fuels [2]. Forces that could move the personal transportation energy sector to diversify its energy inputs in the near future include increasing demand and relatively static supply for petroleum [3], criteria pollutant regulations [4], regulations regarding global climate change [5], fuel price instability [6], and consumer demand for protection against fuel shortages [7].

Fueling transportation using the electricity from the electric grid allows the transportation energy sector to access the lower-cost, cleaner, and higher renewable fraction energy that is present on the electric grid [1]. Battery electric vehicles store electrical energy from the grid electrochemically to provide the vehicle with its only source of energy. The weaknesses of electrochemical energy storage relative to conventional petroleum-based fuels includes low specific energy, low energy density and low refueling/recharging rate [8]. Plug-in hybrid electric vehicles (PHEVs) use both electrochemical energy storage and a conventional fuel to overcome these weaknesses and to provide additional benefits to the consumer and society.

PHEVs are a type of hybrid electric vehicle where some portion of the energy for propulsion of the vehicle comes from the electric grid. In modern PHEVs, the performance difference between an electric vehicle mode, charge-depleting mode and a charge sustaining vehicle mode is nearly imperceptible in performance to the driver. This allows a PHEV to use electric energy to displace petroleum as a transportation fuel, with benefits in terms of increased transportation energy efficiency, reduced carbon emissions, reduced criteria emissions, reduced fueling cost, improved consumer acceptance and improved transportation energy sector sustainability.

Interest in PHEVs is growing among consumers, policy makers, the automobile industry and the electric utilities. Surveys have shown that there exists a considerable market for PHEVs [9–11]. Policy makers and government officials have acknowledged the role that PHEVs will play in bringing on sustainable transportation [11–13]. Both

Renault and Daimler-Chrysler have produced limited production PHEVs [14,15]. General Motors and Ford Motor Company have recently developed and displayed PHEV concept vehicles [16,17].

PHEV research and development has historically been performed by a diverse group of academic, governmental and industrial researchers. This paper presents a review of the recent research on PHEVs. The review encompasses historical and ongoing research into the design and performance of light-duty PHEVs. The emphasis will be on developments in the past 10 years, although these developments will be placed within historical context. The impacts of PHEVs on petroleum consumption, the electric grid, criteria and carbon emissions are summarized. The state of the art of PHEV production and demonstration vehicles is described, and finally a set of research needs for PHEVs is proposed.

2. PHEV design

2.1. Basic design considerations

2.1.1. Vehicle architecture

The components and vehicle architecture of PHEVs are similar to conventional hybrid-electric vehicles, as shown in Fig. 1. Conventionally, both incorporate an electric drivetrain and internal combustion drivetrain that are coupled to each other and to the road. These two drivetrains can be arranged so that the energy paths to the road are in parallel, in series or in a combination of the two. There is a complex tradeoff among these configurations to balance considerations such as efficiency, drivability, cost and manufacturability so that there is no clear globally optimal configuration at this time. PHEVs can be constructed using any of these configurations [14,18,19]. The primary architectural difference between PHEVs and conventional HEVs is the addition of a charger to the PHEV which allows the PHEV to draw and store energy from an electric grid.

2.1.2. Energy management

With both a battery charger and a fuel tank, PHEVs have two sources of energy available on board: stored electrical energy from the grid and stored chemical energy in the form of fuel. By utilizing these energy sources together or separately, PHEVs can be designed and controlled to drive with better performance, higher energy efficiency, lower environmental impact and lower cost than

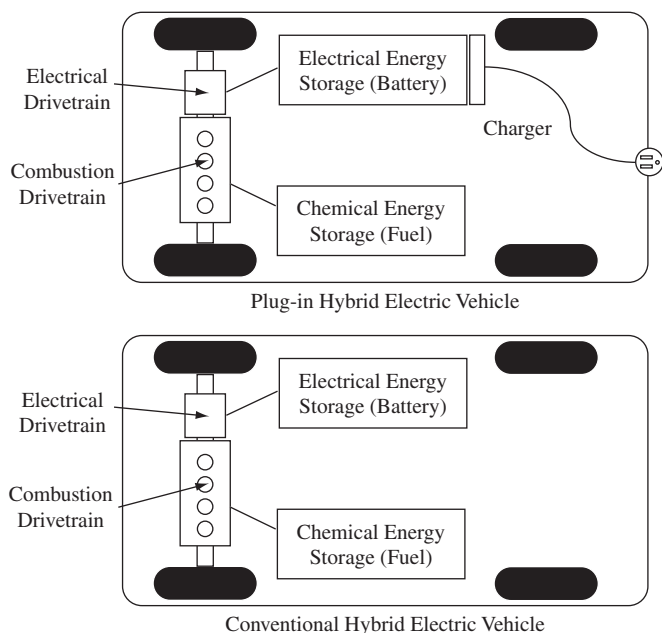

Fig. 1. Architecture of plug-in hybrid electric and hybrid electric vehicles.

conventional HEVs. This is accomplished through control of the vehicle's energy management modes.

Energy management modes dictate both the sources of tractive energy and also the pathways that they take to reach the wheels. PHEVs can operate in a number of energy management modes. Examples of possible energy management modes that are relevant to PHEVs include:

- Charge-sustaining mode—A mode where the battery state-of-charge is controlled to remain within a narrow operating band. This is the mode that conventional HEVs operate in for most of the time [20]. Because the battery state-of-charge does not change with time, liquid fuel is the net source of energy for the vehicle [21,22].
- Charge-depleting mode—A mode where the battery state-of-charge is controlled so as to decrease during vehicle operation. In this mode, the engine may be on or off, but some of the energy for propelling the vehicle is provided by the electrochemical energy storage system, causing the state-of-charge to decrease with time [23,24].
- Electric vehicle (EV) mode—A mode where operation of the fuel converting engine is prohibited. In this mode, the PHEV drives as an electric vehicle. Because the electrochemical energy storage system is the only source of tractive energy, the state of charge decreases with time [21,25,26].
- Engine only mode—A mode where operation of the electric traction system is very limited. In this mode, the electric traction system does not provide tractive power to the vehicle [27,28].

Switching between energy management modes can be automatically controlled as a function of state of charge, vehicle speed, engine speed, engine torque, environment

temperature, battery temperature, air conditioning need, or it can be manually selected by the driver [9,25,29].

Generally, PHEVs are classified based on their energy management modes. *Range extender* PHEVs operate primarily in EV mode and switch to a charge sustaining mode when the vehicle state of charge gets low [25,30]. *Blended* PHEVs operate in a charge depletion mode and switch to a charge sustaining mode when the battery state of charge decreases [31]. *Green Zone* PHEVs operate in a charge sustaining mode, but can be user controlled to operate in EV mode [32]. *Green Zone* PHEVs could be used for operation in no-emissions zones such as inside warehouses or in downtown areas. *HEVX* (e.g. HEV10) PHEVs have the ability to drive a reference driving cycles in electric vehicle mode for *X* miles (e.g. 10 miles, 16 km), although the energy management mode is not always rigidly controlled [9].

2.1.3. Drivetrain function and requirements

The functions of the drivetrain components are dependent on the vehicle architecture and energy management mode. Each energy management mode calls a different energy management control system that controls the function of the electric and combustion drivetrains within the PHEV. For instance, when the vehicle is in a charge-sustaining mode, the vehicle must control the state of charge of the battery by regenerating energy from the combustion drivetrain, using the electric drivetrain to generate electricity. When the vehicle is in electric vehicle mode, the combustion drivetrain will be completely shut off and the electric drivetrain will perform the functions of accelerating and braking the vehicle. Component design and synthesis of the PHEV powertrain is therefore dependent on the specified performance required of the vehicle and the energy management mode. These requirements are particularly important for PHEVs because they are expected to have similar performance in each energy management mode.

In general, the electric drivetrain of the PHEV has very strenuous design requirements that are equivalent to the requirements for HEVs plus the requirements for electric vehicles. Like HEVs, the electric drivetrain of the PHEV must [24,29,33,34]:

- meet a peak power requirement at low speeds during vehicle acceleration;
- meet a peak torque requirement during engine starting;
- be matched in speed range (for parallel systems), or power range (for series systems) to the combustion engine;
- accept high rate accelerations and decelerations during transmission shifts and emergency braking events;
- show fast transient response for engine starting and regenerative braking;
- allow wide input voltage range from the energy storage system;
- incorporate compact packaging to allow integration into a multifunction powertrain.

Like electric vehicles, the electric drivetrain of PHEVs must [33–36]:

- meet a peak power requirement at high speeds during grade climbing or passing maneuvers;
- show low torque ripple to allow for direct to wheel coupling;
- have very high efficiency;
- be controllable at very low speeds and torques during vehicle creep;
- meet HVAC/accessory power requirements of the vehicle during electric vehicle mode.

The internal combustion drivetrain requirements of PHEVs are also very strenuous relative to conventional internal combustion vehicles. The addition of electric vehicle energy management modes places additional requirements such as [37–39]:

- meet emissions control regulations during idle-less cold-start and on–off operation;
- advanced exhaust after-treatment for cold-start and on–off operation;
- meet noise and vibration constraints during on–off operation;
- show high efficiency over a wide torque and speed range;
- high duty cycle due to engine downsizing;
- meet evaporative emissions standards despite long engine off periods.

2.1.4. Energy storage system

Usually electrochemical energy storage for PHEVs consists of batteries, although battery/ultracapacitor [40] and regenerative fuel cell [41–43] PHEVs have been proposed. The functions of the batteries are to store electric energy to propel the vehicle and to meet some short-term power demands of the vehicle. These short-term power demands can be positive in the case of regenerative braking, or they can be negative, in the case of vehicle accelerations. The batteries of PHEVs must perform these functions at a variety of states of charge. Depending on the characteristics of the vehicle the electrical energy stored can be as large as 19 kWh with power transients of > 75 kW for a mid-sized sedan [44], or 30 and > 150 kW for a full-size SUV [29].

As battery replacement is one of the largest potential components of vehicle lifecycle cost, energy storage system lifetime must be on par with the lifetime of other vehicle components. This requirement has been translated into an energy storage lifetime for PHEVs of more than 161,000–210,000 km, 10 years and approximately 2400 charge/discharge cycles [9,45]. For comparison, the Department of Energy FreedomCar program has a calendar battery lifetime goal of 15 years by 2010 [46].

Although early PHEVs incorporated lead-acid (Pb-acid), or nickel–cadmium (NiCd) energy storage systems [24,30], more recent studies have concentrated on using more advanced nickel–metal hydride (NiMH) and lithium ion

(Li-ion) battery chemistries. These later studies have concluded that the lifetime, charge-discharge efficiency, specific energy, and specific power advantages of the advanced battery technologies make up for their higher upfront costs [9,47].

NiMH and Li-ion batteries have been shown to meet the lifetime requirements of PHEVs when subjected to USABC standard test cycles [48,49], which simulate the conditions of use of conventional HEVs. The conditions of use of PHEV batteries are significantly different from those of conventional HEVs. Large daily SOC excursions (up to 80% delta SOC), and high power demands, place high thermal and electrochemical strain on the batteries of PHEVs, which can lower system lifetime [50–52]. EPRI/SCE is currently testing NiMH and Li-ion battery packs using a PHEV-specific test cycle. Preliminary results show less than 5% capacity and power degradation at more than 1500 large SOC excursion cycles [53,54]. This is well above the 20% degradation that signifies end-of-life. Additional testing of batteries in PHEV vehicles will help further refine the battery lifetime requirements for PHEVs.

Among and within battery chemistries there exists a tradeoff between battery maximum power and energy capacity. Batteries for electric vehicles generally are designed with a specific power to specific energy ratio (P/E ratio) of 1–3 whereas HEV batteries are designed with P/E ratios of > 10 [20,55,56]. As PHEVs combine the high energy requirements of electric vehicles and the high power requirements of HEVs, the batteries for PHEVs are a compromise between high-power and high-energy batteries. This is the tradeoff illustrated in Fig. 2. This dual requirement pushes the limits of energy storage technology in a different direction than current applications, requiring specialized chemistries, materials and structures to meet the requirements of PHEVs [31,57].

2.1.5. Grid connection

The charging systems of PHEVs connect the vehicle to an electrical grid. The benefits of PHEVs derive from being able to replace energy from the combustion drivetrain with electric energy from the grid. In order to maximize the effectiveness of the electric energy from the grid the PHEV charger must be light-weight, compact, and of high efficiency. The charger provides an interface between the electrical grid and the vehicle that can be managed by the consumer.

Because the fuel consumption, emissions performance and mode control of PHEVs depend on the state of charge of the energy storage system, the performance of the PHEV is maximized if each trip is started with 100% SOC. This implies that the more often the energy storage system is charged, the better the performance of the vehicle. Most PHEV analyses assume that every vehicle trip starts with a full battery. In practice this ideal cannot be achieved but consumers may charge daily, nightly, or more often as average vehicles are in motion less than 5% of their calendar life [58]. Modern PHEVs can drive in a charge

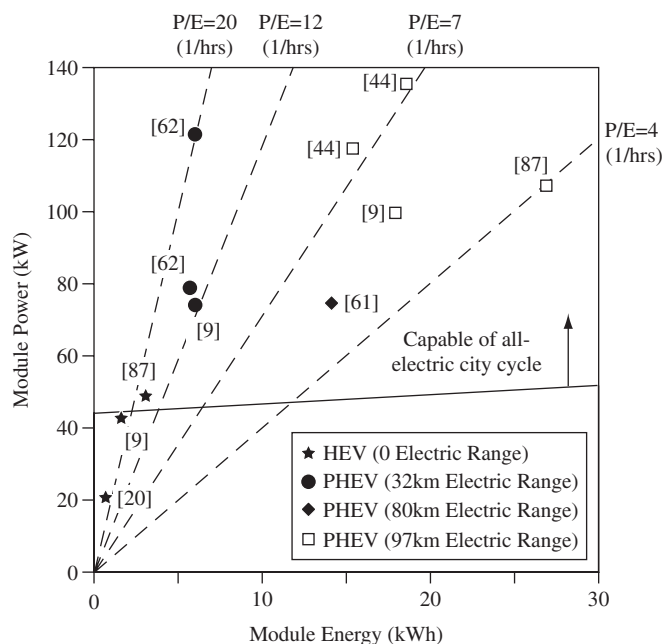

Fig. 2. Battery system power and energy tradeoffs for mid-sized sedan hybrid electric vehicles [87].

sustaining mode when the vehicle has not been charged, so that charging a PHEV is not prerequisite to full function driving of the vehicle, although the fuel cycle energy consumption may change.

The charging rate of PHEVs is determined by the on-vehicle charging hardware, the requirements of the energy storage system and the stationary charging infrastructure. For instance, different battery chemistries require different charging algorithms and charging rates. In order to avoid installation of a high-power charging infrastructure, and to avoid the infrastructure/demand “chicken and egg” problem, PHEVs have been designed to either take advantage of an existing EV charging infrastructure or the standard 1.8 kW (120VAC, 15A in the US) household electric power infrastructure. PHEVs have been designed using either inductive or conductive chargers. Inductive chargers have the advantages of intrinsic safety and preexisting infrastructure associated with the MagneCharge chargers. Conductive chargers have efficiency advantages, are generally lighter weight and more compact [59], and can allow for bidirectional power flow [60].

2.1.6. Other considerations

There are a number of other considerations that must go into the design of PHEVs. The design considerations highlighted above are ones that have a primary effect on the performance and impact of the PHEV. Other design issues that have been investigated in the literature are:

- driveability and consumer acceptability of a vehicle that responds differently during EV and HEV operation [9];
- the effect of component specification on procurement and lifecycle costs [9,62];

- specification and design of accessories systems and HVAC that can function during EV modes of operation [29,63].

2.2. PHEV design studies

The general goals of PHEV design studies, up to the present, have been to determine PHEV performance when compared to other vehicle designs and to determine what the ramifications of PHEV-type driving are on the vehicle components. An example of the first goal might be to compare the fuel economy of PHEVs to HEVs and conventional vehicles. An example of the second goal might be to use the PHEV model to determine what the energy throughput and battery lifetime might be for PHEVs. These goals have limited the scope of the models used to design PHEVs [9,25,28,47,61,62,64–66].

To date, design studies for PHEVs can be characterized as high-level investigations, using a small design space without structured component and controls optimization. Generally, the design studies model the vehicle at the level of powertrain and energy storage component interactions. Lower-level considerations such as battery thermal management, accessory function and transmission control have not yet been fully considered. The design space for the studies cited here is characterized as small because often only a single battery chemistry, engine type or control strategy is considered. In most of the studies cited here, the component specification, control system design and optimization of the PHEV are performed manually by the designer. This intrinsically limits both the performance of the modeled vehicles and the validity of the comparisons drawn within the studies. Further improvements to PHEV design studies are possible with the inclusion of structured optimization and a wider design space.

The design studies cited here agree to some of the general design characteristics of PHEVs such as:

- Parallel PHEV designs are favored because series designs exhibit lower fuel economy, lower efficiency and higher component costs.
- The vehicle energy efficiency and emissions performance improve with increasing energy storage capacity and increasing EV mode or charge depleting mode range. PHEV designs with very large energy storage capacity are limited primarily by their cost rather than performance.
- Advanced technology batteries such as NiMH and Li-ion show the most promise for energy storage mechanisms because of performance, lifetime and lifecycle cost. Pb-acid batteries can match some of the performance metrics of more advanced batteries, but the large depth of discharge required for PHEV use limits their lifetime and increases vehicle lifecycle cost.
- PHEVs should be able to drive functionally and continuously without external recharging. This characteristic allows PHEVs to be full function vehicles that can drive long distances without infrastructure requirements.

- The total output power of a PHEV should be equal to the output power of a conventional HEV to preserve performance and driveability under all conditions. This suggests that as the battery pack power increases, the engine size can decrease. The engine size is generally limited by a vehicle maximum speed and maximum gradeability requirement.
- PHEVs must be designed for present and future emissions and fuel economy standards. For instance, stringent emissions regulations (including on-board diagnostics) might preclude consideration of diesel internal combustion engines for future vehicles in the US [67].

3. Vehicle demonstrations

Technology demonstrator vehicles are key components in the development and assessment of new automotive technologies. Demonstrator vehicles allow the low-level problems associated with any new technology to be discovered and understood. They are also excellent tools for communication of new technologies to funding sources and the public. Table 1 provides a listing with references of all of the PHEV vehicles built to the authors' knowledge since 1997. A summary of the performance and characteristics of a few research and original equipment manufacturer PHEVs is presented in the following sections.

3.1. Research vehicles

An early PHEV was designed and demonstrated between 1978 and 1983 by the US Department of Energy Near Term Hybrid Vehicle Program [30]. The vehicle uses a parallel configuration with a 34 kW electric motor, a 55 kW gasoline engine and Pb-acid batteries. The vehicle drives using a charge depletion scheme that enables a fuel economy between 140 and 27 mpg, depending on number of miles traveled. Student competitions sponsored by the US Department of Energy, the Society of Automotive Engineers and the US auto companies inspired the construction and testing of scores of HEVs [21]. A majority of the HEVs developed for these competitions were PHEVs because most of the HEV designs were based on the *Range extender* HEV design concepts [20].

One of the most technologically advanced and most complete research PHEVs was built at the University of California, Davis in the period 1998–1999 [19]. This PHEV (Coulomb) was a constructed from a Ford prototype aluminum intensive Mercury Sable for the 1999 FutureCar Challenge. The Coulomb had both electric vehicle and charge depletion modes, 49 miles of range in electric vehicle mode, fully functional electric accessories including HVAC, and an automatic continuously variable transmission. A 0.66L Subaru Atkinson cycle engine was fueled by reformulated gasoline. A custom 75 kW electric motor was powered by 60Ah Ovonic NiMH batteries. In an early

design iteration, the charge-sustaining mode fuel economy of the Coulomb is 38 mpg on the combined cycle, and with the addition of its electric vehicle mode range, petroleum consumption is reduced more than 85% over the conventional Mercury Sable. This vehicle has achieved 58 mpg in combined cycle tests after optimization. This vehicle was used to study the effect of engine operation strategies [79] and transmission energy consumption [80] on PHEV fuel economy. Studies of emissions controls [38,81] and engine startup procedures [82] for PHEVs were also accomplished using this vehicle. In addition, Coulomb appeared at dozens of PHEV demonstrations in Japan, France, and across the US, raising awareness of PHEVs. As shown in Table 1, the University of California, Davis, has constructed numerous other light-duty and medium-duty PHEV research vehicles.

3.2. Original equipment manufacturer vehicles

Although a number of manufacturers have constructed proof-of-concept PHEVs, the first production PHEV is the Renault Kangoo Elect'road, which has been in limited production since 2003. The Kangoo Elect'road is a series configuration, *Range extender* PHEV with a 5.5 kW generator set and a 29 kW electric motor. The vehicle is intended for light urban and suburban duty and has a range of 150 km [14].

Daimler-Chrysler has recently developed and is currently evaluating a medium-duty PHEV van, the Dual-Drive Sprinter. The Dual-Drive Sprinter is a parallel hybrid with an 80 kW gasoline engine and a 70 kW electric motor. The vehicle has an EV range of 30 km. NiMH and Li-ion battery chemistries are planned [54].

A number of small companies such as HyMotion, AC propulsion, Energy CS and others have also begun to offer conversions of conventional OEM hybrids to PHEVs. These vehicles are undergoing real-world testing and analysis at a number of commercial and government testing laboratories [58].

4. Sustainability impacts

Based on the results of the body of design studies and vehicle demonstrations described in the preceding sections, the impact of PHEV on the environmental sustainability of the transportation energy sector is beginning to be understood. The sustainability impacts of PHEVs are summarized here based on the results of simulation studies and PHEV demonstration projects. The sustainability of PHEVs is assessed using the metrics of petroleum consumption reduction, criteria emissions reductions, carbon dioxide emissions reductions and the effect of large numbers of PHEVs on the electric grid. These first three metrics correspond to widely accepted sustainability indicators for environmental preservation in transportation [83]. Assessments of the impact on the electric grid provide a means to measure the sustainability of long-term growth in the PHEV market.

Table 1
Characteristics of light-duty plug-in hybrid demonstration vehicles

Vehicle	Year constructed	EV/charge depletion (CD) mode range (km)	Notes	Reference
UC Davis Joule	1996	105 (EV)	0.66L IC engine, NiMH battery	[27]
Audi Duo	1997	50 (EV)	1.9L IC engine, Pb-acid battery	[68]
PSA Dynavolt	1998	100 (EV)	0.2L IC engine, NiCd	[68]
Renault Scenic	1998	20 (EV)	1.6L IC engine, NiCd battery	[68]
UC Davis Coulomb	1998	97 (EV)	0.66L IC engine, NiMH battery	[19]
GM EV1 HEV concept	1998	65 (EV)	1.3L Diesel engine, NiMH battery	[68]
GM EV1 HEV concept	1998	65 (EV)	Natural gas turbine, NiMH battery	[68]
WWU Viking 23	1998	113 (EV)	0.993L IC engine, NiCd battery	[69]
Fiat Multipla	1999	80 (EV)	1.6L IC engine, NiMH battery	[68]
UC Davis HEV1	1999	97 (EV)	0.57L IC engine, NiMH battery	[59]
UC Davis Sequoia	2000	94 (EV)	1.9L IC engine, NiMH battery	[29]
Suzuki EV Sport	2000	150 (EV)	0.393L IC engine, NiMH battery	[70]
Citroen Xsara Dynactive	2000	20 (EV)	1.4L IC engine, NiMH battery	[68]
UC Davis MD CVT Suburban	2001	58 (EV)	2.2L IC engine, Pb-acid battery	[59]
UC Davis Yosemite	2002	79 (EV)	1.9L IC engine, NiMH battery	[71]
Renault Kangoo Elect'road	2003	60 (EV)	0.5L IC engine, NiCd battery	[14]
AC Propulsion PHEV Jetta	2003	64 (EV)	1.4L IC engine, Pb-acid battery	[72]
UC Davis Trinity	2004	64 (EV)	1.5L IC engine, PEMFC, Li-ion battery	[73]
DaimlerChrysler Sprinter PHEV	2005	32 (EV)	2.3L IC engine, NiMH batteries	[15]
CS Energy Prius conversion	2006	71 (CD)	1.5L IC engine, LiFePO ₄ battery	[74]
Hymotion Prius conversion	2006	50 (EV)	1.5L IC engine, LiPolymer battery	[75]
Hymotion escape conversion	2006	80 (EV)	2.3L IC engine, LiPolymer battery	[75]
GM Volt concept	2006	64 (EV)	1.0L E85 IC engine, Li-ion battery	[76]
GM Saturn Vue concept	2006	> 16 (EV)	3.6L IC engine, Li-ion battery	[77]
Ford PHEV Fuel Cell concept	2006	40 (EV)	Fuel cell engine, Li-ion battery	[78]

The performance and impacts of PHEVs are always dependent on the conditions of use of the vehicle. For example, for a PHEV with 30 km of range in electric vehicle mode, the first 30 km of driving after charging is entirely fueled by grid electricity. For a trip of 60 km, approximately half of the energy for propulsion will come from grid electricity and half from petroleum-based fuel.

For any of the sustainability impact studies cited in this review, assumptions are made regarding the driving range, charging frequency, electricity characteristics, electricity sources, and more in order to predict real-world energy consumption and to allow comparison to conventional vehicles. Differences between the assumptions regarding conditions of use account for a majority of the differences between studies. These analyses often incorporate data regarding driving habits from the Nationwide Personal Transportation Survey (NPTS) or National Household Transportation Survey (NHTS) [84,85], the SAE J1711 standard [86], or samples of real-world driving behavior. All of the studies cited here assume that PHEVs are charged nightly. Most importantly, each study incorporates assumptions about the sources and characteristics of the grid electricity used to fuel the PHEV.

4.1. Petroleum consumption

Simulation and testing of PHEVs show that they can offer dramatic reductions in petroleum consumption. The reductions in petroleum consumption for PHEVs as

calculated from recent studies and vehicle demonstrations are shown in Table 2. Each study cited incorporates different assumptions about the conditions of use of the PHEV. For example, when a PHEV with 100 km miles of range in electric vehicle mode is driven according to the NPTS range schedule and charged nightly, the PHEV will result in an 84.1% reduction in gasoline consumption, relative to a conventional car [9]. When charged nightly using real-world driving data, mid-sized sedan PHEVs with 40 miles of EV range result in a 71% reduction in gasoline consumption [58]. For comparison, conventional mid-sized sedan HEVs show a 40–45% reduction in gasoline consumption [87]. In compact cars and mid-sized SUVs the reduction in gasoline consumed is similar [65].

In practice, demonstration vehicles show a very similar reduction in gasoline consumption. A 2000 Chevrolet suburban, converted to PHEV, was tested at General Motors in 2001. When charged nightly and driven with an average driving schedule, the PHEV suburban reduces gasoline consumption as compared to the baseline Suburban by 84% when driven an average driving schedule on the EPA city cycle (LA4) and 80% on the EPA highway cycle (HWFET) [28]. A 2006 Toyota Prius converted to PHEV has achieved a 51% reduction in gasoline consumption, relative to the HEV Prius, during real-world testing [74].

These petroleum reduction figures do not account for the petroleum used to generate electricity as energy from oil makes up less than 3% of the total US electrical energy [1].

Table 2
Gasoline consumption reduction for representative simulated and tested PHEVs

Description	Gasoline consumption reduction (%)	Baseline gasoline consumption (L/100 km)	Notes	Reference
Mid-sized Sedan simulations				
EPRI HEV20 simulation	51.1	8.1	NPTS average driving schedule, charged nightly	[9]
EPRI HEV60 simulation	84.1	8.1	NPTS average driving schedule, charged nightly	[9]
NREL PHEV5 simulation	51.3	10.4	SAE J1711 standard	[87]
NREL PHEV30 simulation	64.2	10.4	SAE J1711 standard	[87]
NREL PHEV60 simulation	88.4	10.4	SAE J1711 standard	[87]
GT PHEV10 simulation	63.0	8.6	Weighted fuel economy	[62]
GT PHEV20 simulation	70.3	8.6	Weighted fuel economy	[62]
GT PHEV40 simulation	80.3	8.6	Weighted fuel economy	[62]
PHEV40 simulation	71	9.0	Surveyed driving schedule and speed	[58]
Mid-sized Sedan test results				
PHEV Taurus Vehicle I	88.4	9.0	Weighted fuel economy	[59]
PHEV Taurus Vehicle II	85.6	9.0	Weighted fuel economy	[59]
PHEV EnergyCS Prius	51.0	4.9	Driver survey Data, Baseline is HEV Toyota Prius	[74]
Sport utility vehicle simulations				
EPRI mid-sized HEV20 SUV simulation	60.0	12.1	NPTS average driving schedule, charged nightly	[65]
EPRI mid-sized HEV60 SUV simulation	85.0	12.1	NPTS average driving schedule, charged nightly	[65]
Sport utility vehicle test results				
PHEV Suburban vehicle city	84	15.1	LA4 fuel economy, NPTS average driving schedule, charged nightly	[59]
PHEV Suburban vehicle highway	80	11.5	HWFET fuel economy, NPTS average driving schedule, charged nightly	[59]

Although variation among the results of the studies cited exists, the large impact of PHEVs on the petroleum consumption of the transportation energy sector is universally acknowledged.

4.2. Criteria emissions

For any vehicle the total emissions must include tailpipe and upstream emissions sources. Upstream emissions sources should include vehicle evaporative emissions, refueling emissions, electricity generation emissions and the emissions associated with fuel extraction, processing, production, transportation and distribution. Criteria emissions are emissions that are regulated for the automotive industry and include hydrocarbons, NO_x, SO_x and particulates. Emissions of CO₂ are considered later in this review.

Because PHEVs carry all of the same engine hardware as conventional vehicles, evaporative emissions are unchanged. Refueling emissions are reduced for PHEVs because of fewer fueling events [9].

The very large reduction in PHEV gasoline consumption should correspond to a large reduction in tailpipe criteria pollutant emissions if PHEVs are able to use state-of-the-art emissions controls. In practice none of the engine management problems associated with PHEVs preclude effective emissions control. Certified emissions testing of

the PHEV suburban conversion has shown SULEV tailpipe emissions levels [59]. The reduced number of cold engine starts, because of trips completed under electric vehicle mode, further reduces the emissions of PHEVs in practice.

The reductions in vehicle tailpipe emissions are offset by an increase in the upstream emissions due to the production and distribution of the electricity consumed by the PHEV. Some simulation studies for PHEVs have shown that the increase in upstream emissions is of lower magnitude than the decrease in tailpipe emissions. For instance, when the electricity is assumed to come from marginal (as opposed to baseline) powerplant capacity, PHEVs can reduce the full fuel cycle sum of NO_x and non-methane organic gases by 44% for the HEV 20, charged nightly [9].

Models of regional electricity sources with load dispatch have been able to break the full fuel cycle emissions into more detailed classes. In the case of large PHEV infiltration into the light-duty vehicle fleet, volatile organic compounds (VOCs) and CO decrease by greater than 90% because of the reduction in internal combustion engine operation. Particulate emissions (PM10) increase slightly, and SO_x emissions increase drastically because of the emissions due to coal-powered powerplants. Since grid electricity is generally generated outside of urban areas where criteria emissions are presently concentrated, all urban emissions are significantly improved [88,89].

The emissions benefits of PHEVs are found to be largely dependent on the means of electricity generation. In electricity markets with low-emissions generation capacity, the emissions benefits of PHEVs are very large. In electricity markets with a coal-based generation capacity, the emissions benefits of PHEVs for reducing VOCs and CO are offset by increases in SO_x and PM10. With increasing market infiltration of PHEVs comes a centralization of the energy production for transportation. The allocation of the criteria emissions for transportation energy to the electrical utilities allows the emissions to be centrally controlled and regulated. For instance, implementation of the federal Clean Air Interstate Rules, Clean Air Mercury Rules, and state Renewable Portfolio Standards will greatly reduce power plants' emissions of SO_x, NO_x and mercury pollutants by 2020 [88]. With reductions in the emissions output of the energy grid due to the implementation of low-emissions energy generation technologies comes improvements in the emissions of PHEV enabled transportation.

4.3. Carbon emissions

As above, an accounting for both tailpipe and upstream emissions sources is required in order to compare the equivalent carbon emissions of PHEVs to HEVs or conventional vehicles [90]. For all of the analyses discussed here, the carbon emissions associated with vehicle produc-

tion are not assessed. For a light-duty PHEV20 with NiMH batteries, the energy consumption associated with manufacture of the battery (2 MWh) is roughly 2.5% of the vehicle's 8-year lifetime energy consumption [9,91]. For conventional vehicles roughly 11% of the lifecycle equivalent CO₂ emissions are associated with vehicle manufacture [92]. As with criteria emissions, the equivalent CO₂ emissions reduction of a particular PHEV trip is dependent on the characteristics of the grid electricity, the length of the trip and the energy management mode of the vehicle [22].

The CO₂ emissions reduction results from various studies are presented in Table 3. The results are divided into three categories based on the methods used to model the electrical grid. First are the results that assume that electricity comes from a single source. For instance, EPRI estimates that the electricity to power PHEVs will come from marginal, dispatchable sources such as natural gas. Under these assumptions, PHEV mid-sized sedans with 20 miles of electric vehicle range are estimated to reduce equivalent carbon dioxide emissions 44% for an average driver, charging nightly [9]. Next are studies that model the electricity generation mix for different geographic regions. Using this methodology a PHEV33 vehicle results in a 27% reduction in carbon dioxide emissions, relative to a conventional vehicle using the 2002 electricity generation mix [89]. Other studies calculate a 16% CO₂ emissions reduction compared to a 2004 Toyota Prius for a PHEV40

Table 3
Carbon dioxide reduction for representative simulated and tested PHEVs

Electricity source model and PHEV type	CO ₂ reduction (baseline CO ₂ emissions)	Notes	Reference
Single electricity source			
Compact car PHEV	40% (200 g/km)	32 km of EV range, surveyed driving habits, COMBINED cycle natural gas generation	[65]
Compact car PHEV	53% (200 g/km)	97 km of EV range, surveyed driving habits, combined cycle natural gas generation	[65]
Mid-sized PHEV	44% (257 g/km)	32 km of EV range, surveyed driving habits, combined cycle natural gas generation	[9]
Mid-sized PHEV	57% (257 g/km)	97 km of EV range, surveyed driving habits, combined cycle natural gas generation	[9]
Mid-sized SUV PHEV	46% (338 g/km)	32 km of EV range, surveyed driving habits, combined cycle natural gas generation	[65]
Mid-sized SUV PHEV	60% (338 g/km)	97 km of EV range, surveyed driving habits, combined cycle natural gas generation	[65]
Full-sized SUV PHEV GM Suburban conversion	67% (514 g/km)	100 km of EV range, NPTS driving habits, US average 2010 generation	[59]
Geographically varied electricity sources			
PHEV fleet with makeup of US vehicle fleet	27% (N/A)	53 km of EV range, surveyed driving habits, 2002 regional electricity generation models	[89]
Mid-sized PHEV	49% (235 g/mi)	64 km of EV range, PHEV fueled for ½ of travel by gasoline, 2005 national generation mix	[88]
Geographically varied, dispatched, future electricity sources			
Mid-sized PHEV	50% (235 g/mi)	64 km of EV range, PHEV fueled for ½ of miles by gasoline, 2020 national generation mix	[88]
Mid-sized PHEV	58% (257 g/km)	32 km of EV range, surveyed driving habits, 2010 regional electricity generation/dispatch model	[93]

[88]. Finally, scenario-based simulations of grid growth, electricity dispatch and geographic generation distribution can be performed to model how sources of PHEV electricity would be generated. Using this most detailed methodology, the CO₂ emissions reduction is calculated to be > 50% for a national average vehicle. Locally, the CO₂ emissions reduction could vary between 69% (western states) and 37% (mid America), compared to conventional vehicles [88,93].

Although there exists some variation among the studies cited here, those studies that power PHEVs using future grid electricity find that PHEVs can achieve a significant reduction in the CO₂ emissions of transportation.

4.4. Electric grid

The source of electrical energy to charge a PHEV can be nearly any regulated source of electrical energy. The nationwide electrical grid, distributed generation microgrids, and dedicated charging sources have all been considered in PHEV studies and demonstrations. Powering PHEVs from microgrids that use sustainable sources of electricity is technologically and economically feasible and has self-evident benefits in terms of all of the above sustainability metrics. In the nearest term, the probable electricity source for large-scale infiltration of PHEVs will be the national electrical grid. For this reason, the impact of large scale introductions of PHEVs on the electric grid must be considered.

There is a great deal of uncertainty associated with modeling of the effect of PHEVs on the grid. Some studies of the effect of PHEVs on the grid assume that the timing of the consumers' charging demands is optimal from the standpoint of the grid operator [89,94–96]. Other studies assume that the consumer will plug in nightly or twice each day to take advantage of the lower per mile cost of electricity [9]. All of these studies agree that even very large numbers of PHEVs (up to 84% of all US cars, trucks and SUVs, 198 million vehicles [89]) could be serviced using the present generation and transmission capacity of the US electrical grid. Instead of adding to the peak generation, PHEVs plugged in during off-peak hours will help to flatten the daily electrical load cycle. This can have the effect of improving grid efficiency and lowering electricity costs [97].

When PHEVs can be combined with schemes for vehicle to grid charging, the benefits to the grid are even greater. Vehicle to grid enabled PHEVs can improve regulation of the electric grid and provide value to the consumer and the electric utility [98]. Recent studies have shown that vehicle to grid charging can provide reserve capacity to allow more development of renewable energy capacity, reducing the amount of electricity generated from coal [95].

5. Research needs for PHEVs

Research has so far focused on the feasibility assessment, design and demonstration of PHEVs. With the recent

expansion of the PHEV research community, the opportunity has come to advance the design, control and analysis of PHEVs toward optimization and production goals.

Fundamental improvements in the lifetime, cost, thermal performance and specific energy of Li-ion battery technology will perhaps have the greatest impact on the performance of PHEVs [99–100]. Battery lifetime and cost are cited as major hurdles that PHEVs must overcome to achieve purchase cost parity with conventional vehicles.

The accelerating pace of PHEV development necessitates improvements in the models used for design of PHEVs. To date, the models that have been used for PHEV design are either custom vehicle modeling programs [101], or else are commercially available programs such as ADVISOR [102], or PSAT [103]. All of these programs are designed for fuel economy prediction and not necessarily for vehicle design and development. For instance, battery lifetime can be adversely affected by the high power transients that can occur during engine startup and transmissions shift shocks. The PHEV models cited here do not have the fidelity to model these high-speed dynamics of the engine and motor interaction and cannot assess the effect of these transients on the battery lifetime.

Optimization of PHEV control strategies and design criteria for consumer acceptability, reduced costs and automotive production requirements will allow for improved real-world performance of PHEVs. Advancements could come with adaptive energy management strategies, in-depth consideration of vehicle accessory performance, and powertrain controls development for improved battery life.

The emphasis on real-world tests and demonstrations of PHEVs should continue. The performance of PHEVs is necessarily dependent on the uses to which they are put. To determine the real-world performance of PHEVs they must be tested in commercial vehicle fleets and with private consumers. As the OEM and research PHEV fleets expand, consumer-derived data regarding consumer preferences, fueling cost, component lifetime and more will become available.

Finally, the analyses of the effect that PHEVs have on the grid must be improved. Many of the current studies use historical data from ANL GREET [104] or other fuel cycle analyses to characterize the electricity used to power PHEVs. This approach does not capture the effect of the changing composition of the grid on the emissions output and energy consumption of PHEVs. A geographic, forward looking and scenario-based model of grid expansion, dispatch and economics is called for to model the impact of emissions reduction regulation, renewable portfolio requirements and changing fueling costs on PHEV performance. These types of simulations can provide guidance to automakers, regulators and policy makers regarding the future costs and benefits of electrical transportation. This change in focus away from modeling of the PHEV toward modeling of the electrical grid will reduce the uncertainty in PHEV performance predictions

and will provide vehicle designers with the information required for optimization of vehicle design.

6. Conclusions

PHEVs were developed by researchers, automakers, utilities and government as a utilitarian answer to the deficiencies of conventional and electric vehicles. The resurgent interest in reducing the energy consumption and improving the sustainability of the personal transportation sector has provided the motivation for advancing the PHEV state of the art. Recent advancements in automotive electric drive systems and battery technologies have made PHEVs technically and commercially possible. This has resulted in a number of demonstration research vehicles and limited production of PHEVs from OEM automobile manufacturers.

A number of recent studies and research vehicle demonstrations have defined the basic design considerations for PHEVs. Optimized energy management strategies are key to the improved performance of PHEVs and characterization of the PHEV requires a detailed understanding of the energy management modes in which a particular vehicle operates. The component performance and system design requirements of PHEVs are demanding because they exhibit many of the same driving modes as both electric and hybrid-electric vehicles. Technological advancements in the energy density, power density and lifetime of electrochemical energy storage batteries have improved the performance and lifecycle cost prospects of PHEVs.

With paper studies regarding the design and optimization of PHEVs have come a number of vehicle demonstrations from both academic researchers and commercial manufacturers. Practical research findings regarding the real-world performance, driveability, consumer acceptability and low-level control of PHEVs have been accomplished using these demonstration vehicles. A few original equipment manufacturers have designed and built PHEVs for limited production.

The body of research on PHEVs shows that PHEVs have significant benefits for the pollution output, energy efficiency and sustainability of the transportation energy sector. All cited studies have shown that PHEVs decrease petroleum consumption relative to conventionally fueled vehicles and hybrid vehicles. PHEVs also reduce criteria emissions under nearly all circumstances by reducing the startups and hours of operation of internal combustion engines. Carbon emissions are significantly reduced for all of the studies cited. A number of studies have shown that the electrical power requirements of PHEVs can be met by the grid for even a very large infiltration of PHEVs.

Ongoing research for PHEVs is addressing their move toward series production. Optimization of real-world performance, cost, component lifetime and consumer acceptability is the newer front of PHEV research.

PHEVs are a promising technology for improving the sustainability of the transportation energy sector. PHEVs achieve this effect by displacing petroleum energy with electrical energy. With PHEVs, the lower emissions, higher efficiency, more sustainable energy from the electrical grid can be used for transportation. As the sources of energy for PHEVs are largely centralized at the electric grid, improvements to the environmental performance, cost or sustainability of the transportation fleet can come from improvements to the grid. Using PHEVs, citizens, municipalities, states or nations can largely determine the emissions output and sustainability of their personal transportation by choosing the sources of their electricity. Given the rising pace of global climate change, petroleum supply pressures, and increasing worldwide vehicle ownership, PHEVs are a means to lower the impact of the transportation energy sector and preserve personal transportation for the future.

References

- [1] Energy Information Administration. Annual energy review 2005. DOE/EIA-0384(2005); 2006.
- [2] Romm J. The car and fuel of the future. *Energy Policy* 2006;34: 2609–14.
- [3] Energy Information Administration. Annual energy outlook 2007 with projections to 2030. DOE/EIA-0383(2007); 2007.
- [4] California Air Resources Board. California exhaust emission standards and test procedures for 2005 and subsequent model zero-emission vehicles, and 2001 and subsequent model hybrid electric vehicles, in the passenger car, light-duty truck and medium-duty vehicle classes; 2003.
- [5] United Nations Climate Change Secretariat. United Nations framework convention on climate change: handbook; 2006.
- [6] Humphreys HB, McClain KT. Reducing the impacts of energy price volatility through dynamic portfolio selection. *Energy Journal* 1998;19(3):107–31.
- [7] Feltus A. Gasoline cap unplugged. *Petr Econ* 2006; 20.
- [8] Ronning JJ. The viable environmental car: the right combination of electrical and combustion energy for transportation. In: SAE international spring fuels and lubricants meeting and exposition, Dearborn, MI, 971629; May 1997.
- [9] Electric Power Research Institute. Comparing the benefits and impacts of hybrid electric vehicle options, Palo Alto, CA, 1000349; 2001.
- [10] Miller A. Consumer drivers: what will it take for plug-in hybrids to compete. In: Plug-in hybrid electric vehicle workshop at 20th international electric vehicle symposium. Long Beach, CA, 15 November 2003.
- [11] Chhatlani J. Study shows strong consumer consideration for flex fuel vehicles including E85 plug-in hybrids peak interest. Synovate Press Release, August 16, 2006.
- [12] Institute for the Analysis of Global Security. Washington, DC: Plug-in hybrid vehicles; 2006.
- [13] Bush GW. State of the union address. Washington, DC; 2006.
- [14] Burgat L. Kangoo reinvents the electric car. Renault Group Press Release, March 10, 2003.
- [15] Sanna L. Driving the solution: the plug in hybrid vehicle. *EPRI J*. 2005; Fall.
- [16] Freeman S. GM pledges to make plug-in hybrid vehicle. *Washington Post*, November 30, 2006.
- [17] Thomas K. Ford unveils plug-in hybrid vehicle. *Washington Post*, January 23, 2007.

- [18] McCurdy, D. PHEV Prius test program by Sacramento Municipal Utility District. In: ZEV technology symposium, Sacramento; CA, [September 25–27, 2006].
- [19] Frank, AA, Johnston BD, McGoldrick T, Funston D, Kwan H, Alexander M, et al. The continued design and development of the University of California, Davis Futurecar. In: SAE international congress and exposition, 980487; February 1998.
- [20] Kelly KJ, Mihalic M, Zolot M. Battery usage and thermal performance of the Toyota Prius and Honda Insight during chassis dynamometer testing. In: 17th annual battery conference on applications and advances, Long Beach, CA, January 14–18, 2002.
- [21] Wipke K. Current hybrid electric vehicle performance based on temporal data from the world's largest HEV fleet. In: 12th international electric vehicle symposium, Anaheim, CA, December 5–7, 1994.
- [22] Badin F, Jeanneret B, Trigui R, Harel F. Hybrid vehicles, should we plug them into the grid or not? In: 18th international electric vehicle symposium, Berlin, Germany; 21–24 October, 2001.
- [23] Riley R, Duvall M, Cobene R, Eng G, Kreutzfeld K, Frank A. Hybrid electric vehicle development at the University of California Davis: the design of Ground FX. SAE, 940340; 1994.
- [24] Kilmer D, Johnston B, Kozin S, Chattot E, Lam SW, McKee A, et al. Development of a parallel hybrid electric vehicle utilizing a charge depletion driving strategy: the UC Davis Aftershock. SAE, SP1170; 1996. pp. 23–32.
- [25] An F, Frank A, Ross M. Meeting both ZEV and PNGV goals with a hybrid electric vehicle: an exploration. SAE, 961718; 1996.
- [26] Burke AF, Smith GE. Impacts of use-pattern on the design of electric and hybrid vehicles. SAE, 810265; 1981.
- [27] Johnston B, McGoldrick T, Funston D, Kwan H, Alexander M, Alioto F, et al. The continued design and development of the University of California, Davis: Davis FutureCar, University of California; 1997.
- [28] Schurhoff RW. The development and evaluation of an optimal powertrain control strategy for a hybrid electric vehicle. Davis: Department of Mechanical and Aeronautical Engineering, University of California; 2002.
- [29] Duvall M, Meyr N, Huff BR, Carde C, Parks J, Schurhoff R, et al. Design and development of the UC Davis FutureTruck. SAE, 2002-01-1210, 2002.
- [30] Trummel MC, Burke AF. Development history of the hybrid test vehicle. IEEE Trans Veh Technol 1983;32:7–15.
- [31] Markel, T, Simpson A. Energy storage systems considerations for grid-charged hybrid electric vehicles. In: SAE future transportation technology and IEEE vehicle power and propulsion joint conferences, Chicago, IL, September 7–9, 2006.
- [32] Graham R, Bradley TH, Duvall M. Development of plug-in hybrid electric light-duty and medium duty commercial vehicles. In: The 20th international electric vehicle symposium and exposition (EVS-20), Long Beach, CA, November 15–19, 2003.
- [33] Miller JM, Schultz SE, Conlon B, Duvall M, Kankam MD, Nagel N. Adjustable speed drives transportation industry needs part I: automotive. In: IEEE 58th vehicle technology conference, Orlando, FL, 6–9 October, 2003.
- [34] Ehsani M, Rahman KM, Toliyat HA. Propulsion system design of electric and hybrid vehicles. IEEE Trans Ind Electron 1997;44:19–27.
- [35] Leonardi F, Degner M. Integrated starter generator based HEVs: a comparison between low and high voltage systems. In: 17th annual battery conference on applications and Advances. Long Beach, CA, January 14–18, 2002.
- [36] Plotkin S, Santini D, Vyas A, Anderson J, Wang M, He J, et al. Hybrid electric vehicle technology assessment: methodology, analytical issues, and interim results. Argonne National Laboratory, ANL/ESD/02-2, 2001.
- [37] Gelman DJ, Perrot TJ. Advanced heat engines for range extender hybrid vehicles. SAE, 930041, 1993.
- [38] Burke AF. On–Off engine operation for hybrid/electric vehicles. SAE, 930042, 1993.
- [39] Struven ND. Experimental facilities and engine studies for a parallel hybrid electric vehicle. Davis: Department of Mechanical and Aeronautical Engineering, University of California; 2002.
- [40] Electric Power Research Institute. Analysis of ultracapacitors for use in a grid-connected electric vehicle, Palo Alto, CA, 1001587; 2002.
- [41] Kalhammer F. Hybridization of fuel cell systems. In: Plug-in hybrid electric vehicle workshop at 20th international electric vehicle symposium, Long Beach, CA, 15 November 2003.
- [42] Suppes GJ, Lopes S, Chiu CW. Plug-in fuel cell hybrids as transition technology to hydrogen infrastructure. Int J Hydrogen Energy 2004;29:369–74.
- [43] Schofield N, Yap HT, Bingham CM. A H2 PEM fuel cell and high energy dense battery hybrid energy source for an urban electric vehicle. In: IEEE international conference on electric machines and drives, 15–18 May; 2005.
- [44] Warf WR, Duvall MS, Moran BD, Frank AA. Battery system requirements for battery dominant hybrid electric vehicles. In: 16th Annual battery conference on applications and advances, Long Beach, CA, 9–12 January, 2001.
- [45] Electric Power Research Institute. Advanced batteries for electric-drive vehicles: a technology and cost-effectiveness assessment for battery electric, power assist hybrid electric, and plug-in hybrid electric vehicles. Palo Alto, California, 1009299; 2003.
- [46] Howell D. Progress report for energy storage research and development. Washington, DC: USDOE; 2006.
- [47] Balch RC, Burke A, Frank AA. The affect of battery pack technology and size choices on hybrid electric vehicle performance and fuel economy. In: Sixteenth annual battery conference on applications and advances, Long Beach, CA, 9–12 January, 2001.
- [48] Rosenkranz C. Deep cycle batteries for plug-in hybrid application. In: Plug-in hybrid electric vehicle workshop at 20th international electric vehicle symposium, Long Beach, CA, 15 November 2003.
- [49] Zahner R, Rodden K, Warf B, MacDougal R. In: Lab testing of NiMH battery packs on four different hybrid control strategies to evaluate life and performance. In: 17th annual battery conference on applications and advances, Long Beach, CA, January 14–18 2002.
- [50] Al-Hallaj S, Kizilel R, Lateef A, Sabbah R, Farid M, Selman JR. Passive thermal management using phase change material (PCM) for EV and HEV Li-ion batteries. In: 2005 IEEE conference on vehicle power and propulsion, Chicago, IL, 7–9 September 2005.
- [51] Andrew M. Lithium-ion: enabling a spectrum of alternate fuel vehicles. In: California air resources board ZEV symposium, Sacramento, CA, 27 September, 2006.
- [52] Ramadass P, Haran B, White R, Popov BN. Capacity fade of Sony 1860 cells cycled at elevated temperatures, Part I cycling performance. J Power Sources 2002;112:606–13.
- [53] Electric Power Research Institute. Test profile development for the evaluation of battery cycle life for plug-in hybrid electric vehicles. Palo Alto, CA, 1002228; 2003.
- [54] Duvall M. Plug-in HEV sprinter van battery considerations and test results. In: ZEV technology symposium, Sacramento, CA, 25–27 September, 2006.
- [55] Ovshinsky SR, Dhar SK, Fetcenko MA, Corrigan DA, Reichman B, Young K, et al. Advanced materials for next generation NiMH portable, HEV and EV batteries. IEEE Aerosp Electron Syst Mag 1999;May:17–23.
- [56] Duvall M. Introduction to plug-in hybrid electric vehicles. In: Plug-in hybrid electric vehicle workshop at 20th international electric vehicle symposium, Long Beach, CA, 15 November 2003.
- [57] Menjak I, Gow PH, Corrigan DA, Venkatesan S, Dhar SK, Stempel RC et al. Advanced Ovonic high-power Nickel–metal hydride

- batteries for hybrid electric vehicle applications. In: 13th annual battery conference on applications and advances, Long Beach, CA, 13–16 January, 1998.
- [58] Markel T. Plug-in hybrid electric vehicles. In: clean cities congress and exposition, Phoenix, Arizona, 7–10 May, 2006.
- [59] Frank AA. Battery dominant hybrid electric vehicle systems development and evaluation. Diamond Bar, CA: South Coast Air Quality Management District, 2002, 01022.
- [60] Kempton W, Tomic J, Letendre S, Brooks A, Lipman T. Vehicle to grid power: Battery, hybrid and fuel cell vehicles as resources for distributed electric power in California. University of California, Davis Institute for Transportation Studies; 2001, UCD-ITS-RR-01-03.
- [61] An F, Barth M, Scora G. Impacts of diverse driving cycles on electric and hybrid electric vehicle performance. Society of Automotive Engineers Technical Paper Series, 972646.
- [62] Golbuff S. Optimization of a plug-in hybrid electric vehicle. Georgia Institute of Technology: George Woodruff School of Mechanical Engineering; 2006.
- [63] Alexander M, Johnston B, Funston B, Carlson R, Meyr N, Moran B, et al. A Mid-sized sedan designed for high fuel economy and low emissions: the 1999 UC Davis FutureCar. University of California, Davis Institute for Transportation Studies; 2001, UCD-ITS-RR-99-11.
- [64] Reimers GJ. A comparative investigation of nine optimized hybrid electric vehicle powertrains to determine the viability of a 2.94L/100 km (80 mpg) automobile capable of reducing exhaust emissions. Davis: Department of Mechanical and Aeronautical Engineering, University of California; 1996.
- [65] Electric Power Research Institute. Comparing the benefits and impacts of hybrid electric vehicle options for compact sedan and sport utility vehicles. Palo Alto, California, 1006892; 2002.
- [66] An F, Barth M. Critical issues in quantifying hybrid electric vehicle emissions and fuel consumption. In: SAE future transportation technology conference & exposition. Costa Mesa, CA, 981902; August 1998.
- [67] Cackette T. Light-duty diesels: clean enough? In: Diesel engine-efficiency and emissions research (DEER) conference presentations, Detroit, MI, 20–24 August, 2006.
- [68] Smokers RTM, Dijkhuizen AJJ, Winkel RG. Hybrid vehicles overview report 2000. International Energy Agency, Hybrid Electric Vehicle Implementing Agreement; 2000.
- [69] Seal MR. Viking 23: zero emissions in the city, range and performance on the freeway. In: IEEE Northcon/94, 11–13 October, 1994.
- [70] Suzuki EV-Sport. Automotive engineering international online: global concepts (Part 2), 10 October, 2000.
- [71] Meyr N, Carde C, Nitta C, Garas D, Garrard T, Parks J, et al. Design and development of the UC Davis FutureTruck. In: SAE world congress and exposition, Detroit, Michigan; 2003-01-1263, March, 2003.
- [72] Cocconi A, Gage T. Connected cars: battery electrics and plug in hybrids. In: Seattle electric vehicle to grid forum, Seattle, Washington, 6 June, 2005.
- [73] Singer-Englar AM, Kamisky RJ, Erickson PA, Frank, AA, Allan W, et al. Design and development of a parallel hybrid powertrain for a high-performance sport utility vehicle. In: Powertrain and fluid systems conference and exposition, San Antonio, TX; 2005-01-3827, October, 2005.
- [74] MacCurdy D. PHEV Prius test program by Sacramento Municipal Utility District. In: ZEV technology symposium, 25–27 Sacramento, CA, September, 2006.
- [75] Hymotion Canada. Product literature. Ontario, Canada, retrieved 12 March, 2007. <<http://www.hymotion.com/products.htm>>.
- [76] Chevrolet Volt—GM's concept electric vehicle—could nearly eliminate trips to the gas station. General Motors Press Release, Detroit, MI, 7 January 2007.
- [77] GM announces intention to produce plug-in hybrid SUV. General Motors Press Release, Detroit, MI, 29 November, 2006.
- [78] Ford unveils world's first drivable fuel cell hybrid electric vehicle with plug-in capability. Ford Motor Company Press Release, Washington, DC, 23 January, 2007.
- [79] Francisco AB. Implementation of an ideal operating line control strategy for hybrid electric vehicles. Davis: Department of Mechanical and Aeronautical Engineering, University of California; 2002.
- [80] Bradley TH, Huff BR, Frank AA. Energy consumption test methods and results for servo-pump continuously variable transmission control system. SAE Tran J Fuels and Lubricants 2005. 2005-01-3782.
- [81] Vaughn JDW. Emissions control and optimization of a plug-in, battery dominant, charge depletion hybrid-electric vehicle. Davis: Department of Mechanical and Aeronautical Engineering, University of California; 2002.
- [82] Funston DP. An investigation of an open loop control strategy for the reduction of vehicle bucking caused by engine clutch engagement in a parallel hybrid electric vehicle. Davis: Department of Mechanical and Aeronautical Engineering, University of California; 2000.
- [83] Jeon CM, Amekudzi A. Addressing sustainability in transportation systems: definitions, indicators and metrics. J Infrastructure Syst 2006;11:31–50.
- [84] Nationwide personal transportation survey. US Department of Transportation, Bureau of Transportation Statistics; 1995.
- [85] National household transportation survey. US Department of Transportation, Bureau of Transportation Statistics; 2002.
- [86] Society of Automotive Engineers. Recommended practice for measuring the exhaust emissions and fuel economy of hybrid-electric vehicles. Hybrid Committee, March 1999, J1711.
- [87] Simpson A. Cost-benefit analysis of plug-in hybrid electric vehicle technology. In: 22nd international battery, hybrid and fuel cell electric vehicle symposium and exposition (EVS-22), Yokohama, Japan, October 23–28, 2006.
- [88] Kliesch J, Langer T. Plug-in hybrids: an environmental and economic performance outlook. American Council for an Energy-Efficient Economy, September 2006, T061.
- [89] Kintner-Meyer M, Schneider K, Pratt R. Impacts assessment of plug-in hybrid vehicles on electric utilities and regional US power grids, Part 1: technical analysis. Pacific Northwest National Laboratory; 2006.
- [90] Sullivan JL. Sustainability metrics for vehicles. Pure Appl Chem 2001;73:1273–6.
- [91] Gaines L, Singh M. Energy and environmental impacts of electric vehicle battery production and recycling. In: SAE total life cycle conference and exposition, Vienna, Austria, 951865, 16–19 October, 1995.
- [92] Burnham A, Wang M, Wu Y. Development and applications of GREET 2.7—the transportation and vehicle-cycle model. Argonne, IL, 2006, ANL/ESD/06-5.
- [93] Clark C. Environmental benefits of plug-in hybrid electric vehicles. In: ZEV technology symposium, Sacramento, CA; 25-27 September, 2006.
- [94] Denholm P, Short W. An evaluation of utility system impacts and benefits of optimally dispatched plug-in hybrid electric vehicles. National Renewable Energy Laboratory Technical Report NREL/TP-620-40293; 2006.
- [95] Short W, Denholm P. A preliminary assessment of plug-in hybrid electric vehicles on wind energy markets. National Renewable Energy Laboratory Technical Report NREL/TP-620-39729; 2006.
- [96] Lemoine D, Kammen DM, Farrell AE. Effects of plug-in hybrid electric vehicles in California energy markets. Berkeley: Environmental and Resource Economics Seminar, University of California; September 20, 2006.
- [97] Scott MJ, Kintner-Meyer M, Elliot DB, Warwick WM. Impacts assessment of plug-in hybrid vehicles on electrical utilities and

- regional US power grids, Part 2: economic assessment, Pacific Northwest National Laboratory; 2006.
- [98] Kempton W, Tomic J. Vehicle-to-grid power fundamentals: calculating capacity and net revenue. *J Power Sources* 2005;144:268–79.
- [99] Santini, DJ. Hearing on plug-in hybrid electric vehicles. US Congress House Committee on Science, Energy Subcommittee, 17 May, 2006.
- [100] US Department of Energy. Plug-in hybrid electric vehicle R&D plan: external draft. Washington, DC, 28 February, 2007.
- [101] Powell BK, Pilutti TE. A range extender hybrid electric vehicle dynamic model. In: Proceedings of the 33rd conference on decision and control, Lake Buena Vista, FL, December 1994.
- [102] Gmbh AVL. ADVISOR. Austria: Graz; 2007.
- [103] Argonne National Laboratory, Powertrain systems analysis toolkit. Argonne, IL; 2007.
- [104] Argonne National Laboratory, The greenhouse gases, regulated emissions, and energy use in transportation (GREET) model. Argonne, IL; 2007.